

Bulletin Officiel de la Propriété Industrielle (BOPI)

Brevets d'inventions

PUBLICATION

N° 06 BR / 2014

du 21 Octobre 2015

Organisation
Africaine de la
Propriété
Intellectuelle



SOMMAIRE

TITRE	PAGES
PREMIERE PARTIE : GENERALITES	2
Extrait de la norme ST3 de l'OMPI utilisée pour la représentation des pays et organisations internationales	3
Extrait de la norme ST9 de l'OMPI utilisée en matière de documentation des Brevets d'Invention et des Modèles d'Utilité	6
Codes utilisés en matière d'inscriptions dans les registres spéciaux des Brevets d'Invention et des Modèles d'Utilité	6
Clarification du règlement relatif à l'extension des droits suite à une nouvelle adhésion à l'Accord de Bangui	7
Adresses utiles	8
DEUXIEME PARTIE : BREVETS D'INVENTION	9
Repertoire numérique du N° 16466 au N° 16515	10
Repertoire suivant la C.I.B	33
Repertoire des noms	35

**PREMIERE PARTIE
GENERALITES**

Extrait de la norme ST.3 de l'OMPI

Code normalisé à deux lettres recommandé pour la représentation des pays ainsi que d'autres entités et des organisations internationales délivrant ou enregistrant des titres de propriété industrielle.

Afghanistan	AF	Cook, Îles	CK
Afrique du Sud	ZA	Corée (République de Corée)	KR
Albanie	AL	Corée (Rép. Populaire de Corée)	KP
Algérie	DZ	Costa Rica	CR
Allemagne	DE	Côte d'Ivoire*	CI
Andorre	AD	Croatie	HR
Angola	AO	Cuba	CU
Anguilla	AI	Danemark	DK
Antigua-et-Barbuda	AG	Djibouti	DJ
Antilles Néerlandaises	AN	Dominicaine, République	DO
Arabie Saoudite	SA	Dominique	DM
Argentine	AR	Egypte	EG
Arménie	AM	El Salvador	SV
Aruba	AW	Emirats Arabes Unis	AE
Australie	AU	Equateur	EC
Autriche	AT	Erythrée	ER
Azerbaïdjan	AZ	Espagne	ES
Bahamas	BS	Estonie	EE
Bahreïn	BH	Etats-Unis d'Amérique	US
Bangladesh	BD	Ethiopie	ET
Barbade	BB	Ex Rep. Yougoslavie de Macedoine	MK
Bélarus	BY	Falkland, Îles (Malvinas)	FK
Belgique	BE	Fédération de Russie	RU
Belize	BZ	Fidji	FJ
Bénin*	BJ	Féroé, Îles	FO
Bermudes	BM	Finlande	FI
Bhoutan	BT	France	FR
Bolivie	BO	Gabon*	GA
Bonaire, Saint-Eustache et Saba	BQ	Gambie	GM
Bosnie-Herzégovine	BA	Géorgie	GE
Botswana	BW	Géorgie du Sud et les Îles Sandwich du Sud	GS
Bouvet, Île	BV	Ghana	GH
Brésil	BR	Gibraltar	GI
Brunéi Darussalam	BN	Grèce	GR
Bulgarie	BG	Grenade	GD
Burkina Faso*	BF	Groenland	GL
Burundi	BI	Guatemala	GT
Caïmanes, Îles	KY	Guernesey	GG
Cambodge	KH	Guinée*	GN
Cameroun*	CM	Guinée-Bissau*	GW
Canada	CA	Guinée Equatoriale*	GQ
Cap-Vert	CV	Guyana	GY
Centrafricaine, République*	CF	Haïti	HT

Chili	CL	Honduras	HN
Chine	CN	Hong Kong	HK
Chypre	CY	Hongrie	HU
Colombie	CO	Île de Man	IM
Comores*	KM	Îles Vierges (Britanniques)	VG
Congo*	CG	Inde	IN
Congo(Rép.Démocratique)	CD	Indonésie	ID
Iran(République Islamique d')	IR	Norvège	NO
Iraq	IQ	Nouvelle-Zélande	NZ
Irlande	IE	Oman	OM
Islande	IS	Ouganda	UG
Israël	IL	Ouzbékistan	UZ
Italie	IT	Pakistan	PK
Jamaïque	JM	Palaos	PW
Japon	JP	Panama	PA
Jersey	JE	Papouasie-Nouvelle-Guinée	PG
Jordanie	JO	Paraguay	PY
Kazakhstan	KZ	Pays-Bas	NL
Kenya	KE	Pérou	PE
Kirghizistan	KG	Philippines	PH
Kiribati	KI	Pologne	PL
Koweït	KW	Portugal	PT
Laos	LA	Qatar	QA
Lesotho	LS	Région admin. Spéciale de Hong Kong (Rep. Populaire de Chine)	HK
Lettonie	LV	Roumanie	RO
Liban	LB	Royaume Uni (Grande Bretagne)	GB
Libéria	LR	Rwanda	RW
Libye	LY	Sahara Occidental	EH
Liechtenstein	LI	Sainte-Hélène	SH
Lituanie	LT	Saint-Kitts-et-Nevis	KN
Luxembourg	LU	Sainte-Lucie	LC
Macao	MO	Saint-Marin	SM
Macédoine	MK	Saint-Marin (Partie Néerlandaise)	SX
Madagascar	MG	Saint-Siège(Vatican)	VA
Malaisie	MY	Saint-Vincent-et-les Grenadines(a,b)	VC
Malawi	MW	Salomon, Îles	SB
Maldives	MV	Samoa	WS
Mali*	ML	SaoTomé-et-Principe	ST
Malte	MT	Sénégal*	SN
Mariannes du Nord, Îles	MP	Serbie	RS
Maroc	MA	Seychelles	SC
Maurice	MU	Sierra Leone	SL
Mauritanie*	MR	Singapour	SG
Mexique	MX	Slovaquie	SK
Moldova	MD	Slovénie	SI
Monaco	MC	Somalie	SO

Mongolie	MN	Soudan	SD
Monténégro	ME	SriLanka	LK
Montserrat	MS	Suède	SE
Mozambique	MZ	Suisse	CH
Myanmar(Birmanie)	MM	Suriname	SR
Namibie	NA	Swaziland	SZ
Nauru	NR	Syrie	SY
Népal	NP	Tadjikistan	TJ
Nicaragua	NI	Taiwan,Province de Chine	TW
Niger*	NE	Tanzanie (Rép.-Unie)	TZ
Nigéria	NG	Tchad*	TD
Thaïlande	TH	Tchèque,République	CZ
Timor Oriental	TP	Ukraine	UA
Togo*	TG	Uruguay	UY
Tonga	TO	Vanuata	VU
Trinité-et-Tobago	TT	Venezuela	VE
Tunisie	TN	VietNam	VN
Turkménistan	TM	Yémen	YE
Turks et Caïques,Îles	TC	Yougoslavie	YU
Turquie	TR	Zambie	ZM
Tuvalu	TV	Zimbabwe	ZW

ORGANISATIONS INTERNATIONALES DELIVRANT OU ENREGISTRANT DES TITRES DE PROPRIETE INDUSTRIELLE

Bureau Benelux des marques et des dessins et modèles industriels	BX
Office Communautaire des variétés végétales (Communauté Européenne (OCVV))	QZ
Office de l'harmonisation dans le marché intérieur (Marque, dessins et modèles)	EM
Office des Brevets du conseil de Coopération des Etats du Golf (CCG)	GC
Office Européen des Brevets (OEB)	EP
Organisation Mondiale de la Propriété Intellectuelle (OMPI)	WO
Bureau International de l'OMPI	IB
Organisation Africaine de la Propriété Intellectuelle (OAPI)	OA
Organisation Eurasienne des Brevets (OEAB)	EA
Organisation Régionale Africaine de la Propriété Industrielle (ARIPO)	AP

*Etats membres de l'OAPI

**CODES UTILISES EN MATIERE DE DOCUMENTATION DES
BREVETS D'INVENTION ET DES MODELES D'UTILITE**

- (11) Numéro de publication.
- (12) Désignation du type de document.
- (19) Identification de l'office qui publie le document.
- (21) Numéro d'enregistrement ou de dépôt.
- (22) Date de dépôt.
- (24) Date de délivrance.
- (30) Pays dans lequel (lesquels) la(les) demande(s) de priorité a (ont) été déposée(s).
Date(s) de dépôt de la (des) demande(s) de priorité.

(le cas échéant)

Numéro(s) attribué(s) à la (aux) demande(s) de priorité.

- (51) Classification internationale des brevets(CIB).
- (54) Titre de l'invention.
- (57) Abrégé.
- (60) Références à d'autres documents apparentés (le cas échéant).
- (71) Nom(s) du ou des demandeur(s).
- (72) Nom de l'inventeur (le cas échéant) suivi éventuellement du nom de la société d'appartenance.
- (73) Nom(s) du ou des titulaire(s) le cas échéant.
(Ce code n'apparaît que sur la première page du brevet délivré)
- (74) Nom du mandataire en territoire OAPI (le cas échéant).

**CODES UTILISES EN MATIERE D'INSCRIPTIONS
DANS LE REGISTRE SPECIAL DES BREVETS D'INVENTION ET DES
MODELES D'UTILITE**

- (1) Numéro de délivrance
- (2) Numéro de dépôt
- (3) Numéro et date de la demande d'inscription
- (4) Nature de l'inscription
- (5) Numéro et date de l'inscription
- (10) Cédant
- (11) Cessionnaire
- (12) Apporteur
- (13) Bénéficiaire
- (14) Dénomination avant
- (15) Dénomination après
- (16) Concédant
- (17) Titulaire
- (18) Ancienne adresse
- (19) Nouvelle adresse
- (20) Constituant du nantissement
- (21) Créancier nanti

CLARIFICATION DU REGLEMENT RELATIF A L'EXTENSION DES DROITS SUITE A UNE NOUVELLE ADHESION A L'ACCORD DE BANGUI

RESOLUTIONN°47/32

LE CONSEIL D'ADMINISTRATION DE L'ORGANISATION AFRICAINE DE LAPROPRIETE INTELLECTUELLE

- Vu L'accord portant révision de l'accord de Bangui du 02 Mars 1977 instituant une Organisation Africaine de la Propriété Intellectuelle et ses annexes ;
- Vu Les dispositions des articles 18 et 19 dudit Accord relatives Aux attributions et pouvoirs du Conseil d'Administration ;

ADOPTE la clarification du règlement du 04 décembre 1988 relatif à l'extension des droits suite à une nouvelle adhésion à l'Accord de Bangui ci-après :

Article 1er :

Le Règlement du 04 décembre 1988 relatif à l'extension des droits suite à une nouvelle adhésion à l'Accord de Bangui est réaménagé ainsi qu'il suit :

« Article 5 (nouveau) » :

Les titulaires des titres en vigueur à l'Organisation avant la production des effets de l'adhésion d'un Etat à l'accord de Bangui ou ceux dont la demande a été déposée avant cette date et qui

voudront étendre la protection dans ces Etats doivent formuler une demande d'extension à cet effet auprès de l'Organisation suivant les modalités fixées aux articles 6 à 18 ci-dessous.

Le renouvellement de la protection des titres qui n'ont pas fait l'objet d'extension avant l'échéance dudit renouvellement entraîne une extension automatique des effets de la protection à l'ensemble du territoire OAPI».

Le reste sans changement.

Article 2 :

La présente clarification, qui entre en vigueur à compter du 1^{er} janvier 2008, s'applique aussi aux demandes d'extension en instance et sera publiée au Bulletin Officiel de l'Organisation.

Fait à Bangui le 17 décembre 2007

STRUCTURES NATIONALES DE LIAISON (SNL)

BENIN-Cotonou

Agence Nationale de la Propriété Industrielle (ANAPI)

Tel.: (229) 21 31 02 40
Fax.: (229) 21 30 30 24
01 B.P. 363 Cotonou 01

BURKINA FASO-Ouagadougou

Direction Nationale de la Propriété Industrielle (DNPI)

(Ministère de l'Industrie, du Commerce et de l'Artisanat)
Tél. : (226) 50 30 09 41
Fax : (226) 50 33 05 63
01 B.P. 258 Ouagadougou

CAMEROUN-Yaoundé

Direction du Développement Technologique et de la Propriété Industrielle

(Ministère des Mines, de l'Industrie et du Développement Technologique)
Tel. : (237) 22 20 37 78
Fax: (237) 22 20 37 38
B.P. 1652 Yaoundé

CENTRAFRIQUE-Bangui

Direction de la Propriété Industrielle (Ministère du Commerce et de l'Industrie)

Tél. : (236) 21 61 17 44
Fax : (236) 21 61 76 53
Avenue B. BOGANDA
B.P. 1988 Bangui

COMORES-Moroni

Office comorien de la propriété intellectuelle

Tél. : 269 333 53 60
Fax : 269 775 00 03
B.P. 41 Moroni

CONGO-Brazzaville

Antenne Nationale de la Propriété Industrielle (ANPI)

(Ministère du Développement Industriel et de la Promotion du Secteur Privé)
Tél. : (242) 581 56 57
Fax : (242) 581 54 80
B.P. : 72 Brazzaville

COTE D'IVOIRE-Abidjan

Office Ivoirien de la Propriété Industrielle (OIPD)

Tel. : (225) 20 33 53 43/44
Fax: (225) 20 33 53 45
01 B.P. 2337 Abidjan

GABON-Libreville

Centre de la Propriété Industrielle du Gabon (CEPIG)

(Ministère du Commerce et du Développement Industriel, Chargé du NEPAD)
Tel. : (241) 01 74 59 24
Fax : (241) 01 76 30 55
B.P. : 1025 Libreville

GUINEE-Conakry

Service National de la Propriété Industrielle

(Ministère de l'Industrie, des Petites et Moyennes Entreprises)
Tel. : (224) 30 41 17 20/60 58 53 61
Fax: (224) 41 25 42/41 39 90
B.P. 468 Conakry

GUINEE BISSAU-Bissau

Direction Générale de la Propriété Industrielle

(Ministère du Commerce, de l'Industrie et de la Promotion des Produits locaux)
Tél : (245) 322 22 75
Fax : (245) 322 37 65
B.P. : 269 Bissau

GUINEE EQUATORIALE-Malabo

Direction de la Propriété Intellectuelle

(Conseil de la Recherche Scientifique et Technique - CICTE)
Tel. : (240) 222 09 24 84
Fax : (240) 333 09 33 13
B.P. : 528 Malabo

MALI-Bamako

Centre Malien de la Propriété Industrielle (CEMAPI)

Tel. : (223) 20 29 90 90
Fax: (223) 20 29 90 91
B.P. : 278 Bamako

MAURITANIE-Nouakchott

Service de la Technologie et de la Propriété Industrielle

(Ministère du Commerce, de l'Industrie, de l'Artisanat et du Tourisme)
Tel. : (222) 525 72 66
Fax: (222) 525 69 37
B.P. : 387 Nouakchott

NIGER-Niamey

Direction de l'Innovation et de la Propriété Intellectuelle

(Ministère des Mines et du Développement Industriel)
Tél. : (227) 20 73 58 25
Fax : (227) 20 73 21 50
B.P. : 480 Niamey

SENEGAL-Dakar

Agence Sénégalaise pour la Propriété Industrielle et l'Innovation Technologique (ASPIT)

Tel. : (221) 33 869 47 70
Fax: (221) 33 827 30 14
B.P. : 4037 Dakar

TCHAD-N'djamena

Division de la Propriété Industrielle et de la Technologie

(Ministère du Commerce et de l'Industrie)

Tel. : (235) 22 52 08 67
Fax: (235) 22 52 21 79
B.P. : 424 N'Djamena

TOGO-Lomé

Institut National de la Propriété Industrielle et de la Technologie (INPIT)

Tel. : (228) 222 10 08
Fax : (228) 222 44 70
B.P. : 2339 Lomé



OAPI

B.P. 887 Yaoundé-Cameroun Tél : (237) 22 20 57 00

E-mail : oapi@oapi.int

Fax : (237) 22 20 57 27

www.oapi.int

DEUXIEME PARTIE
BREVETS D'INVENTION

A

REPertoire NUMERIQUE

(11) **16466**

(51) A61K 9/08; A61K 9/00; A61K 31/485

A61K 33/395

(21) 1201200298 - PCT/US11/020457

(22) 07.01.2011

(30) US n° 61/293,227 du 08/01/2010

US n° 12/986,223 du 07/01/2011

(54) Stabilized formulations containing anti-interleukin-6 receptor (IL-6R) antibodies.

(72) DIX, Daniel, B.; GRAHAM, Kenneth, S.;

KAMEN, Douglas, E.; WALSH, Scott, M.

(73) Regeneron Pharmaceuticals, Inc. (US)

(74) Cabinet Spoor & Fisher Inc. Ngwafor & Partners, Blvd. du 20 Mai, Immeuble Centre Commercial de l'Hôtel Hilton, 2è Etage, Porte 208A, B.P. 8211, YAOUNDE (CM).

(57) The present invention provides pharmaceutical formulations comprising a human antibody that specifically binds to human interleukin-6 receptor (hIL-6R). The formulations may contain, in addition to an anti-hIL-6R antibody, at least one amino acid, at least one sugar, and/or at least one non-ionic surfactant. The pharmaceutical formulations of the present invention exhibit a substantial degree of antibody stability after storage for several months.

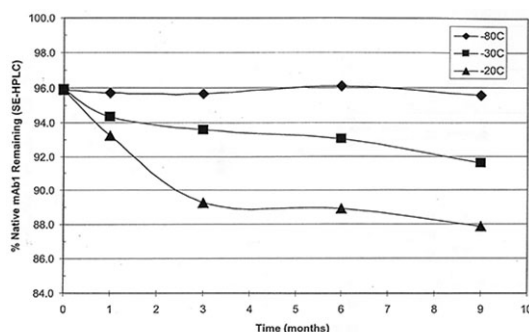

Figure 1

[Consulter le mémoire](#)(11) **16467**

(51) C01B 15/047; C22B 60/02

(21) 1201300260 - PCT/EP11/073132

(22) 16.12.2011

(30) FR n° 1061249 du 24/12/2010

(54) Method for converting UO_3 and/or U_3O_8 into hydrated UO_4 .

(72) MOREL Bertrand; AMARAGGI David; ARAB Mehdi; THOMAS Rudy; RIVENET Murielle; ABRAHAM Francis.

(73) COMURHEX SOCIETE POUR LA CONVERSION DE L'URANIUM EN METAL ET HEXAFLUORURE, ZI du Tricastin, 26701 PIERRELATTE (FR)

(74) Cabinet CAZENAVE SARL, B.P. 500, YAOUNDE (CM).

(57) The invention relates to a method for converting UO_3 and/or U_3O_8 into hydrated UO_4 having the formula $\text{UO}_4 \cdot n\text{H}_2\text{O}$, where n is 2 or 4, including the following consecutive steps: a) preparing an aqueous suspension of a UO_3 powder and/or a U_3O_8 powder; b) adding hydrogen peroxide H_2O_2 to the aqueous suspension of UO_3 and/or U_3O_8 powder, converting the UO_3 and/or U_3O_8 into hydrated UO_4 , and precipitating and crystallizing the hydrated UO_4 in the suspension; c) recovering the hydrated UO_4 precipitate; d) optionally washing the hydrated UO_4 precipitate; e) optionally repeating step d); and f) optionally drying the precipitate, wherein the addition of H_2O_2 to the aqueous suspension is carried out such that the suspension contains a stoichiometric excess of H_2O_2 with respect to the stoichiometry of the reaction from UO_3 : $\text{UO}_3 + n\text{H}_2\text{O} + \text{H}_2\text{O}_2 \rightarrow \text{UO}_4 \cdot n\text{H}_2\text{O} + \text{H}_2\text{O}$ (1) or of the reaction from U_3O_8 : $\text{U}_3\text{O}_8 \cdot 0.67 + 1.33 \text{H}_2\text{O}_2 + n\text{H}_2\text{O} \rightarrow \text{UO}_4 \cdot n\text{H}_2\text{O} + \text{H}_2\text{O}$ (2), and the pH of the suspension is maintained in steps a) and b) at a value between 2 and 4.

[Consulter le mémoire](#)(11) **16468**

(51) C23C 16/50 (2006.01)

(21) 1201300363 - PCT/US12/028125

(22) 07.03.2012

(30) US n° 13/042,611 du 08/03/2011

(54) Systems and methods for activation and deactivation of appliances.

(72) RICKET, Douglas, J.

(73) D. LIGHT DESIGN, INC. (KY)

(74) SCP AKKUM, AKKUM & Associates, Quartier Mballa II, Dragages, B.P. 4966, YAOUNDE (CM).

(57) Systems and methods are provided for an appliance system. The system includes an

appliance, and a processor connected to the appliance such that the processor places the appliance in one of an enabled state and a disabled state. The processor is configured to track usage of the appliance and to place the appliance in a disabled state when the usage of the appliance exceeds a threshold amount. The system also includes a data receiving device configured to receive a code, wherein upon receipt of a valid code, the processor is configured to adjust the threshold amount to allow additional usage of the appliance.

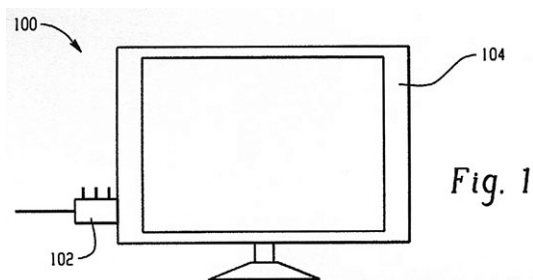

[Consulter le mémoire](#)

(11) **16469**

(51) A01N 29/04; A61K 31/025

(21) 1201300264 - PCT/US11/066690

(22) 22.12.2011

(30) US n° 61/426,379 du 22/12/2010

(54) Bicyclo[3.2.1]octyl amide derivatives and uses of same.

(72) LI, Guiying; ZHOU, Hao; WEISS, Jesse; DOLLER, Dario; FORD, James.

(73) H. Lundbeck A/S (DK)

(74) Cabinet Spoor & Fisher Inc. Ngwafor & Partners, Blvd. du 20 Mai, Immeuble Centre Commercial de l'Hôtel Hilton, 2è Etage, Porte 208A, B.P. 8211, YAOUNDE (CM).

(57) The present invention provides bicyclo[3.2.1]octyl amide derivatives of formula (I) :

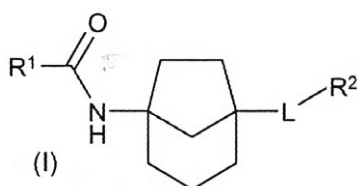

wherein L, R¹ and R² are as defined herein, or a pharmaceutically acceptable salt thereof;

pharmaceutical compositions and methods using the same.

[Consulter le mémoire](#)

(11) **16470**

(51) A61F 17/00

(21) 1201300267 - PCT/FR11/053068

(22) 20.12.2011

(30) FR n° 1061258 du 24/12/2010

(54) Kit pour le traitement des envenimations.

(73) CHERIF ZAHAR Kamal (FR)

(74) Cabinet CAZENAVE SARL, B.P. 500, YAOUNDE (CM).

(57) L'objet de l'invention est un kit pour le traitement des envenimations caractérisé qu'il comprend au moins : une seringue (12) avec aiguille, remplie d'un liquide pour anesthésie locale et vasoconstriction, un bistouri (14) comportant une lame avec un limiteur (20) de profondeur d'incision, et une seringue (16) avec aiguille, remplie d'un liquide de lavage incluant les mêmes composés que ceux de la seringue (12) mais à une concentration inférieure. Un tel kit permet d'extraire localement en urgence le venin d'une morsure ou piqûre inoculée par un animal venimeux. L'invention couvre aussi le procédé de mise en oeuvre du kit.

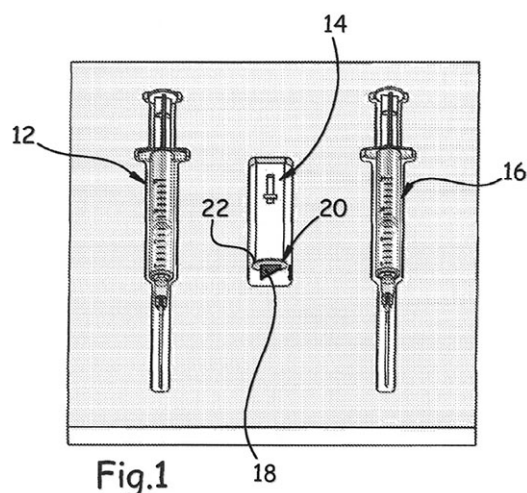

[Consulter le mémoire](#)

(11) **16471**

(51) B62J 23/00 (2006.01)

(21) 1201300268

(22) 28.06.2013

(30) IN n° 2591/CHE/2012 du 29/06/2013

(54) Handle bar cover for a motorcycle.

(72) Rengarajan Babu; Bharat Arvind Rajput; Palanisamy Nandakumar; Thanikachalam Gunalan; Shailesh Kumar.

(73) TVS MOTOR COMPANY LIMITED (IN)

(74) FORCHAK IP & LEGAL ADVISORY, 3rd Floor, Viccul Building, Apt. 15-16, Carr Street, Behind Police Barracks, New Town, B.P. 370, LIMBE (CM).

(57) The present invention relates to a novel handle bar cover for partially covering a handle bar an upper bracket which is removably attachable to a handle bar assembly at least at three locations. It comprises of a neck present in a posterior portion of the handle bar cover, each of them further comprising additional elements. The handle bar cover is also functional as an ignition lock cover and a steering shaft cover and is devoid of excessive compressive forces on its surface due to its construction.

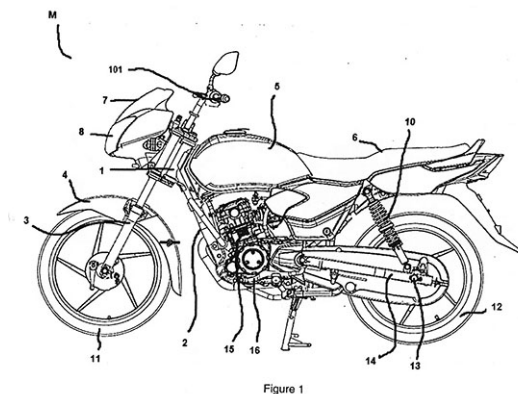

Figure 1

[Consulter le mémoire](#)

(11) **16472**

(51) F16L 1/15 (2006.01)

(21) 1201300269 - PCT/EP12/050057

(22) 03.01.2012

(30) FR n° 1150045 du 04/01/2011

(54) Dispositif de pose d'une conduite dans une étendue d'eau, structure et procédé associés.

(72) MALOBERTI René; LEGEAY Sébastien; BONNEMAISON Didier; THIBAUT Yannick.

(73) TECHNIP France (FR)

(74) Cabinet CAZENAVE SARL, B.P. 500, YAOUNDE (CM).

(57) Ce dispositif comporte une tour (30) destinée à faire saillie suivant un axe de tour (B-B') dans une structure de pose flottante (10) et des ensembles (34A, 34B) de saisie et de déplacement de la conduite (12) pour guider le déplacement de la conduite (12) vers l'étendue d'eau (11) suivant un axe de pose (C-C'). Chaque ensemble de saisie et de déplacement (34A, 34B) est porté par la tour (30). La tour (30) est formée par un fût (32) s'étendant le long de l'axe de tour (B-B'), le ou chaque ensemble de saisie faisant saillie transversalement à partir du fût (32) par rapport à l'axe de tour (B-B').

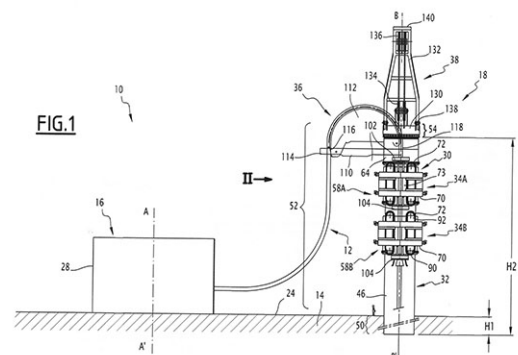

[Consulter le mémoire](#)

(11) **16473**

(51) A61K 31/195; A61K 8/00; A61P 17/00

(21) 1201300270

(22) 18.06.2013

(54) Produit naturel pour l'hydratation et le traitement de l'hyperpigmentation de la peau.

(73) Madame LAUBHOUET née LAVRY Blah Joachine, 18 B.P. 1100, ABIDJAN 18 (CI).

(57) L'invention concerne un produit naturel constitué de racines de la plante Uvaria afzelii tubercules de la plante Syperus articulatus, feuilles des plantes Isolana cooperi et Monathotaxis capea. Ces différentes parties des plantes susmentionnées sont incorporées dans l'huile de palme brute préalablement chauffée pendant 1h30min. Le filtrat obtenu est un produit naturel préconisé pour l'hydratation et le traitement de l'hyperpigmentation de la peau.

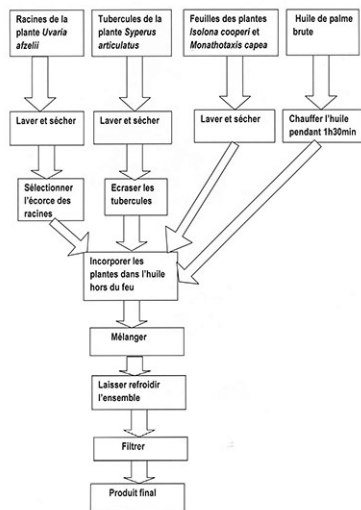

[Consulter le mémoire](#)

(11) **16474**

(51) A61K 35/64; A61K 36/185; A61P 3/10
A61P 3/04

(21) 1201300271

(22) 10.06.2013

(54) Substance naturelle pour le traitement du diabète.

(73) BAMBA Biti, 09 B.P. 30, ABIDJAN 09 (CI).

(57) L'invention concerne une substance naturelle issue de la plante tropicale *Olyra Latifolia* du genre Poaceae, utilisées pour le traitement du diabète et de la plaie diabétique.

Les feuilles de la plante *Olyra Latifolia* sont séchées à l'ombre, triées, bouillies et filtrées. Le filtrat obtenu est une solution buvable préconisée dans le traitement du diabète et des maladies opportunistes qui en sont issues telles que les plaies diabétiques et les courbatures diabétiques.

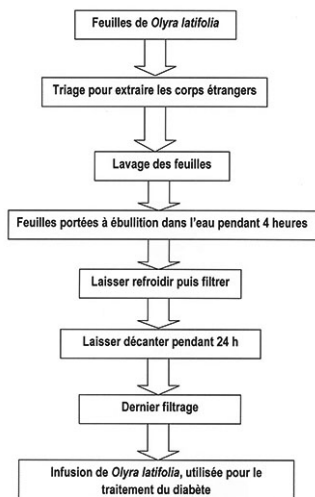

[Consulter le mémoire](#)

(11) **16475**

(51) C05F 15/00

(21) 1201300274

(22) 10.06.2013

(54) Engrais organique à base de vermicompost de résidus de cacao.

(73) KONAN Kouassi Sylvain, 13 B.P. 1809, ABIDJAN 13 (CI).

(57) L'invention concerne un engrais organique utilisé en agriculture pour la fertilisation des sols. Il utilise des coques et cabosses de cacao abandonnées pour la production d'engrais biologique par la méthode du vermicompostage.

Des coques et cabosses de cacao sont finement broyées puis décomposées par des vers de terre en milieu anaérobie et en milieu aérobie successivement. Une minéralisation organique est apportée au produit ainsi qu'un liant organique en vue de l'enrichir en certains minéraux.

DIAGRAMME DE FABRICATION

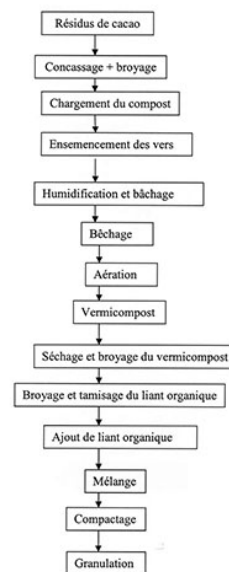

[Consulter le mémoire](#)

(11) **16476**

(51) C07C 233/18; C07C 231/14; C07D 209/48

(21) 1201300278 - PCT/FR12/000004

(22) 04.01.2012

(30) FR n° 11.00023 du 05/01/2011

(54) Nouveau procédé de synthèse de l'agomélatine.

(72) ZARD Samir; SIRE Béatrice; BOUMEDIENE Mehdi.

(73) LES LABORATOIRES SERVIER (FR)

(74) Cabinet EKANI-CONSEILS, B.P. 5852, YAOUNDE (CM).

(57) Procédé de synthèse industriel du composé de formule (I)

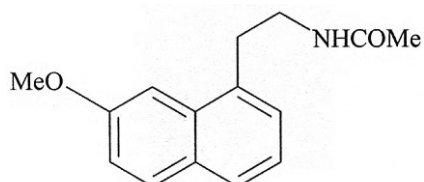

[Consulter le mémoire](#)

(11) **16477**

(51) C07C 231/02; C07C 233/18; C07C 253/30
C07C 255/37

(21) 1201300279 - PCT/FR12/000005

(22) 04.01.2012

(30) FR n° 11.00024 du 05/01/2011

(54) Nouveau procédé de synthèse de l'agomélatine.

(72) ZARD Samir; SIRE Béatrice; BOUMEDIENE Mehdi.

(73) LES LABORATOIRES SERVIER(FR)

(74) Cabinet EKANI-CONSEILS, B.P. 5852, YAOUNDE (CM).

(57) Procédé de synthèse industriel du composé de formule (I)

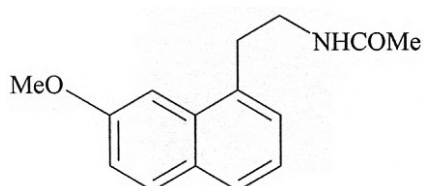

[Consulter le mémoire](#)

(11) **16478**

(51) C07D 407/14; A61P 3/10; A61K 31/454
A61P 5/50

(21) 1201300281 - PCT/EP12/050841

(22) 20.01.2012

(30) EP n° 11151688.6 du 21/01/2011

EP n° 11191903.1 du 05/12/2011

(54) Fused dihydrofurans as GPR119 modulators for the treatment of diabetes, obesity and related disorders.

(72) HIMMELSBACH Frank; LANGKOPF Elke; NOSSE Bernd.

(73) Boehringer Ingelheim International GmbH (DE)

(74) Cabinet ÉKÉMÉ LYSAGHT SARL, B.P. 6370, YAOUNDE (CM).

(57) The present invention relates to compounds of general formula (I),

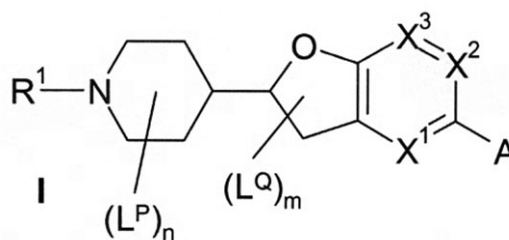

wherein the groups R^1 , L^P , L^Q , X^1 , X^2 , X^3 , A , n and m are as defined in the application, which have valuable pharmacological properties, and in particular bind to the GPR119 receptor and modulate its activity.

[Consulter le mémoire](#)

(11) **16479**

(51) C07D 403/12; C07D 407/12; C07D 409/12
A61P 29/06

(21) 1201300282 - PCT/EP12/050830

(22) 20.01.2012

(30) EP n° 11151876.7 du 24/01/2011

(54) Pyrazole compounds as CRTH2 antagonists.

(72) ANDERSKEWITZ Ralf; MARTYRES Domic; OOST Thorsten; RIST Wolfgang; SEITHER Peter.

(73) Boehringer Ingelheim International GmbH (DE)

(74) Cabinet ÉKÉMÉ LYSAGHT SARL, B.P. 6370, YAOUNDE (CM).

(57) The present invention relates to pyrazole compounds of formula (1a) or (1b) and pharmaceutically acceptable salts thereof,

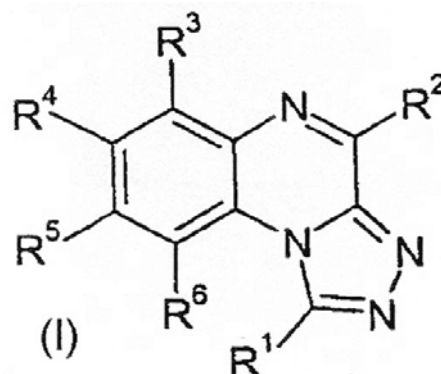
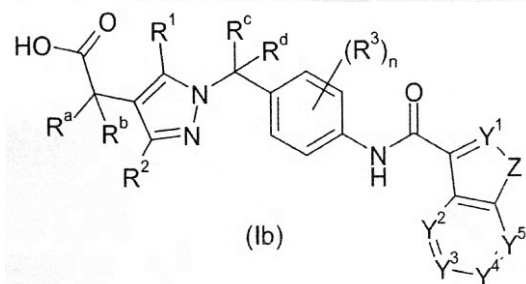
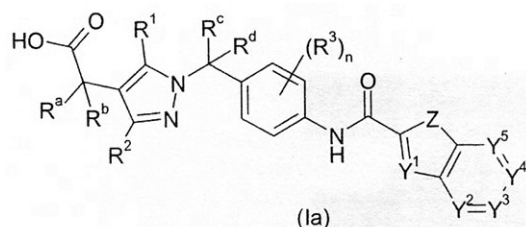

Formule I

[Consulter le mémoire](#)

wherein R^a , R^b , R^c , R^d , Y^1 , Y^2 , Y^3 , Y^4 , Y^5 , Z , R^1 , R^2 , n and R^3 have one of the meanings as indicated in the specification and claims, to their use as medicaments, to pharmaceutical formulation containing said compounds and to pharmaceutical formulations said compounds in combination with one or more active substances.

[Consulter le mémoire](#)

(11) **16480**

(51) C07D 487/04; A61P 25/00; A61K 31/519

(21) 1201300283 - PCT/EP12/051546

(22) 31.01.2012

(30) US n° 61/437848 du 31/01/2011

(54) (1,2,4) triazolo[4,3-A]quinoxaline derivatives as inhibitors of phosphodiesterases.

(72) LANKAU Hans-Joachim; LANGEN Barbara; GRUNWALD Christian; HÖFGEN Norbert; STANGE Hans; DOST Rita; EGERLAND Ute.

(73) Boehringer Ingelheim International GmbH (DE)

(74) Cabinet ÉKÉMÉ LYSAGHT SARL, B.P. 6370, YAOUNDE (CM).

(57) The invention relates to (1,2,4)triazolo[4,3-a] quinoxaline derivatives of formula (I) which are inhibitors of phosphodiesterase 2 and/or 10, useful in treating central nervous system diseases.

(11) **16481**

(51) C22B 1/02; C22B 60/02; C22B 59/00

(21) 1201300284 - PCT/EP12/050188

(22) 06.01.2012

(30) FR n° 1150089 du 06/01/2011

(54) Dissolution and recovery of at least one element Nb or Ta and of at least one other element U or rare earth elements from ores and concentrates.

(72) AGIN Jérôme; DURUPT Nicolas; GRECO Antoine; THIRY Jacques; HAMMY Fatima; LAROCHE Guillaume.

(73) 1 - AREVA MINES (FR)

2 - ERAMET (FR)

(74) Cabinet CAZENAVE SARL, B.P. 500, YAOUNDE (CM).

(57) The main subject-matter of the present invention is a process for the dissolution of at least one element chosen from niobium and tantalum and at least one other element chosen from uranium and the rare earth elements, advantageously for the dissolution of niobium, tantalum, uranium and rare earth elements, present in an ore or an ore concentrate. Said process comprises :

- the roasting of a material, comprising said elements, which material is mixed, dry or/in the presence of water, with an acid roasting agent in order to obtain a calcine; said material consisting of said ore or concentrate or having been obtained from said ore or said concentrate and said acid roasting agent providing for roasting in a sulphate medium; and

- the dissolution in an aqueous solution of the calcine obtained in order to obtain a slurry, the liquid fraction of which includes iron, in the ferric state, at a concentration of at least 50 g/l, advantageously of at least 70 g/l and very advantageously of at least 120 g/l.

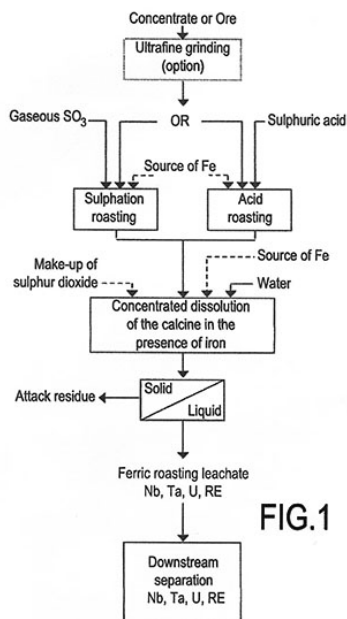

FIG.1

[Consulter le mémoire](#)

(11) **16482**

(51) A23F 5/24; A23F 5/26; A23F 5/28

(21) 1201300290

(22) 28.06.2013

(54) Café soluble obtenu par goutte à goutte à base des graines vertes du caféier et des extraits des essences du *Xylopiya aethiopica*.

(72) NDAW Mohamed.

(73) SAQARA, 26, Route des Aéroports, Yoff, B.P. 25086, DAKAR (SN).

(57) L'invention concerne un café soluble obtenu par goutte à goutte à base de graines vertes du caféier et des extraits d'essences du *xylopiya aéthiopica*.

Les graines vertes du caféier et les extraits des essences du *xylopiya aéthiopica* sont transformées de manière séparée en poudre de fine granulométrie par les techniques classiques de la torréfaction, de la monture et du tamisage.

Ensuite on a procédé à un mélange de résultat obtenu par un dosage basé sur une clef de 10/1.

Pour obtenir le goutte à goutte, la poudre obtenue par le mélange est versée dans des sachets filtrés

de onze grammes et comportant des crochets qui peuvent être accrochés sur une tasse.

Le sachet filtré dont le tissu en gaz azoté permet de garder le goût.

[Consulter le mémoire](#)

(11) **16483**

(51) A61K 9/70; A61K 33/519

(21) 1201300291 - PCT/EG11/000004

(22) 22.03.2011

(30) EG n° 2011010144 du 23/01/2011

(54) Bio super vegetable gardens (BSVG).

(73) MANSOUR, Rawya Lofty (MC)

(74) SCP AKKUM, AKKUM & Associates, Quartier Mballa II, Dragages, B.P. 4966, YAOUNDE (CM).

(57) The objective of this invention "Bio Super Vegetable Gardens" is to obtain the highest bio-productivity of some cash vegetables crops per unit area by planting them utilizing a friendly environment technology, through the addition of organic waste to the soil, e.g. plant wastes (rice straw and compost) and animal wastes (chicken manure), Bentonite or Biochar, Mixture of natural minerals, bio-polymers and efficient micro-organisms (EM). Thus, improving its chemical, physical and biological soil properties and hence increasing its productivity. Furthermore, the soil is surrounded with plastic sheet to keep essential nutrients and water from leakage. After that, the "Gardens" are cultivated with 4 rotation cycle by different kinds of vegetables. This technology yields a 40% higher output and saving 60% of irrigation water, compared to traditional untreated soils.

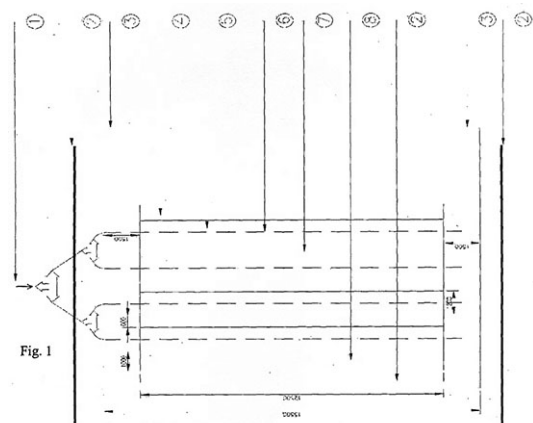

[Consulter le mémoire](#)

(11) **16484**

(51) A61K 31/12; A61K 31/12; A61P 13/12

(21) 1201300294 - PCT/US12/022118

(22) 20.01.2012

(30) US n° 61/435,201 du 21/01/2011

US n° 61/544,910 du 07/10/2011

(54) Methods and compositions for treating kidney disorders.

(72) LIU, Sheng-Yung; HWANG, San-Bao.

(73) GOLDEN BIOTECHNOLOGY CORPORATION (CN)

(74) SCP AKKUM, AKKUM & Associates, Quartier Mballa II, Dragages, B.P. 4966, YAOUNDE (CM).

(57) The present invention provides methods for treating glomerulosclerosis such as focal segmental glomerulosclerosis (FSGS) or glomerulonephritis such as immunoglobulin A nephropathy (IgAN) by cyclohexenone compounds.

Fig. 1A-C

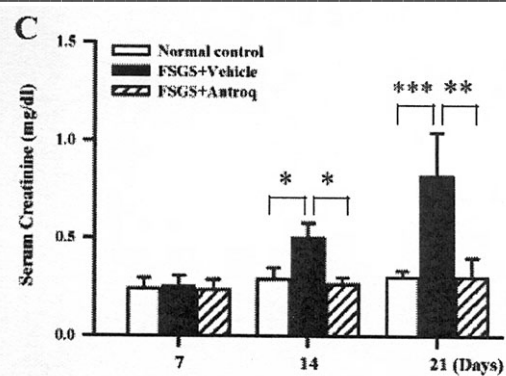
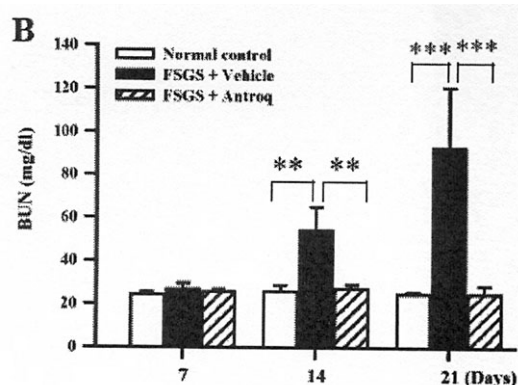
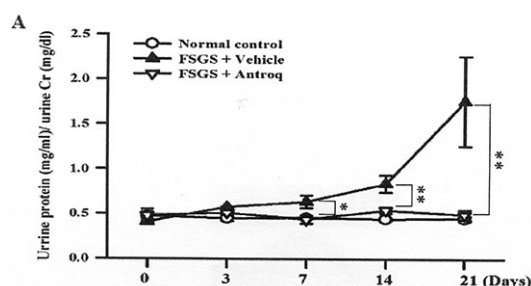
[Consulter le mémoire](#)(11) **16485**(51) C07D 239/70; C07D 403/12; A61K 31/517
A61P 11/00

(21) 1201300297 - PCT/EP12/051298

(22) 27.01.2012

(30) EP n° 11152895.6 du 01/02/2011

(54) 9-[4-(3-chlor-2-fluor-phenylamino)-7-methoxy-quinazolin-6-yloxy]-1,4-diazaspiro[5.5]undecan-5-one dimaleate, use thereof as a drug, and production thereof.

(72) OSTERMEIER Markus; PFRENGLE Waldemar; HUCHLER Guenther; SIEGER Peter.

(73) Boehringer Ingelheim International GmbH (DE)

(74) Cabinet ÉKÉMÉ LYSAGHT SARL, B.P. 6370, YAOUNDE (CM).

(57) The invention relates to a compound of formula (I),

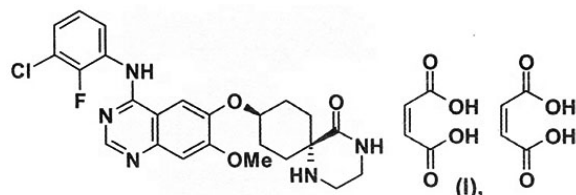

which has valuable pharmacological properties, in particular an inhibiting effect on signal transduction mediated by tyrosine kinases, processes for stereoselectively preparing these compounds, particularly pharmaceutical formulations suitable for inhalation, and their use for the treatment of diseases, particularly tumoral diseases, benign prostatic hyperplasia and diseases of the lungs and airways.

[Consulter le mémoire](#)

(11) **16486**

(51) B01D 69/12 (2006.01)

(21) 1201300298 - PCT/CA11/000093

(22) 24.01.2011

(54) Composite membranes for membrane distillation and related methods of manufacture.

(72) QTAISHAT Moh'd Rasool; MATSUURA Takeshi; KHAYET Mohamed.

(73) Membrane Distillation Desalination Ltd. Co., P.O. Box 926992, AMMAN 11190 (JO)

(74) Cabinet ÉKÉMÉ LYSAGHT SARL, B.P. 6370, YAOUNDE (CM).

(57) The present invention provides composite membranes for membrane distillation and related methods of manufacture. In particular, there is provided a composite hydrophilic/hydrophobic membrane comprising a hydrophilic polymer layer and a hydrophobic polymer layer comprising fluorinated surface-modifying macromolecules, wherein said composite membrane has a high vapour flux. There is also provided methods of manufacturing and optimizing the composite membranes and a membrane distillation system comprising the composite membranes.

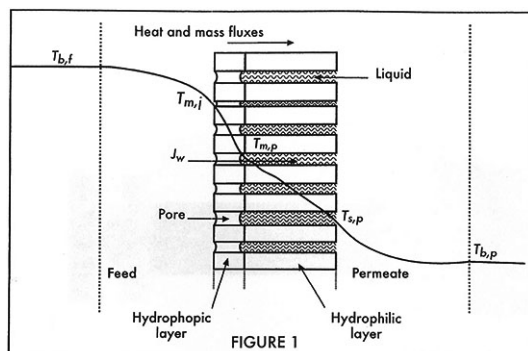

FIGURE 1

[Consulter le mémoire](#)(11) **16487**

(51) B01D 69/12 (2006.01)

(21) 1201300299 - PCT/CA12/000045

(22) 19.01.2012

(30) CA n° PCT/CA2011/000093 du 24/01/2011

(54) Composite mixed matrix membranes for membrane distillation and related methods of manufacture.

(72) QTAISHAT Moh'd Rasool; KHAYET Mohamed; MATSUURA Takeshi; ALMUTTIRI Saad.

(73) Membrane Distillation Desalination Ltd. Co. (JO)

(74) Cabinet ÉKÉMÉ LYSAGHT SARL, B.P. 6370, YAOUNDE (CM).

(57) The present invention relates to a membrane distillation system comprising a flat-sheet composite mixed matrix hydrophilic/hydrophobic membrane having at least a hydrophilic layer and a hydrophobic layer. The hydrophilic layer comprises a hydrophilic polymer and inorganic nanoparticles having high thermal conductivity. The hydrophobic layer comprises fluorinated surface-modifying macromolecules (SMM). Also disclosed is a phase inversion method for manufacturing the membrane.

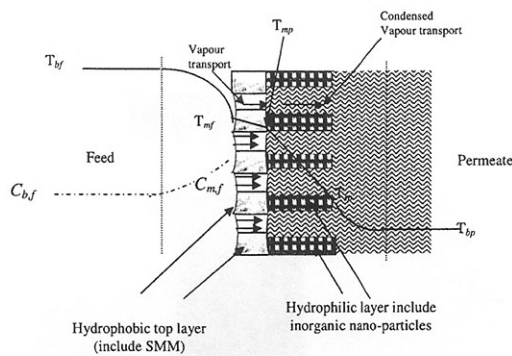

FIGURE 1

[Consulter le mémoire](#)(11) **16488**

(51) C22B 1/24

(21) 1201300301

(22) 23.07.2013

(30) US n° 61/674,633 du 23/07/2012

(54) Process for the optimized production of iron ore pellets.

(72) PIMENTA, Hamilton Porto; BOTELHO, Marcus Edouardo Emrich.

(73) VALE S.A. (BR)

(74) SCP AKKUM, AKKUM & Associates, Quartier Mballa II, Dragages, B.P. 4966, YAOUNDE (CM).

(57) The present invention describes an advantageous and effective streamlined process for the production of iron ore pellets, the green pellets replacing the burnt pellets for covering the metallic surface in "travelling grate" furnace during the burning step, the process comprising at least some or all of the steps of grinding the iron ore; filtering the crushed iron ore; mixing the filtered iron or with at least one binder; pelletizing the

mixture; drying the green pellets; transferring the pellets to the side and bottom grids of a "travelling grate" furnace equipment and screening the burnt iron ore pellets.

An optimized process for the production of iron ore pellets is provided that is innovative, efficient and economical when compared to currently known processes.

[Consulter le mémoire](#)

(11) **16489**

(51) E21B 43/00 (2006.01)

(21) 1201300302

(22) 06.06.2013

(54) Aéroextracteur d'air.

(73) NDIAYE Abidine, Boune- Médina Rassoul, B.P. 14921, DAKAR-PEYTAVIN (SN).

(57) La présente invention a pour objet, un aéroextracteur destiné à extraire l'air pollué, les gaz dans un local.

Le dispositif essentiel de l'invention est constitué de pales en inox ou en aluminium sur lesquelles s'exerce la pression de l'air.

L'intérêt principal de l'invention est qu'il fonctionne sans aucun carburant et à une longue durée de vie.

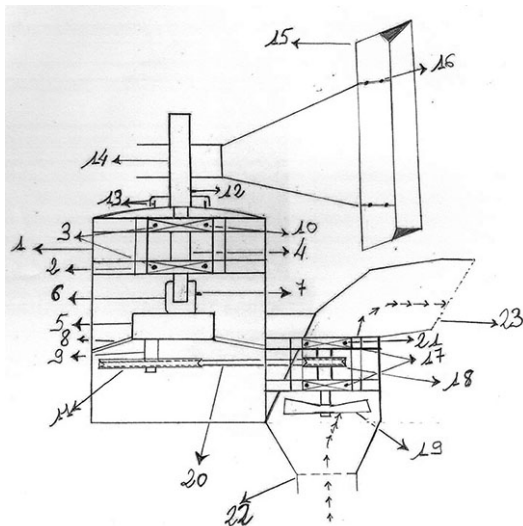

[Consulter le mémoire](#)

(11) **16490**

(51) B23F 23/12 (2006.01)

(21) 1201300304

(22) 03.07.2013

(54) Système de distribution et de contrôle électronique de l'assurance "prépayée".

(73) CISSE Sidy Alpha, Sicap Amitié 3 n° 4600, DAKAR (SN).

(57) L'invention concerne un système de distribution et de contrôle électronique, de l'assurance prépayée basée sur le traitement automatisé de l'ensemble des opérations dans la chaîne de distribution et de contrôle de l'assurance.

Le système fait intervenir pour son fonctionnement cinq acteurs de la chaîne de distribution à savoir les points de vente, les établissements financiers, une plateforme, les clients et les compagnies d'assurance.

Le système s'applique à toutes les formes d'assurance du secteur et permet un contrôle à la source au niveau de la plateforme.

[Consulter le mémoire](#)

(11) **16491**

(51) H04M 3/42 (2006.01)

(21) 1201300305 - PCT/MD12/000001

(22) 17.01.2012

(30) MD n° S 20110195 du 17/03/2011

(54) Method for notification of a called subscriber in the absence of sufficient credit of the calling party.

(73) NICOLAESCU, Gheorghe (MD)

(74) Cabinet ISIS CONSEILS (SCP), B.P. 15067, YAOUNDE (CM).

(57) The invention relates to telephone communication, in particular to methods for notification of the called subscriber in the communication networks, namely in the absence of the calling party's valid credit account, and can be used in existing mobile telecommunications systems, including GSM, 3 GSM, 3G, CDMA, WCDMA, and others.

In the method each subscriber of the network is provided with an opportunity to get network access for outgoing calls, regardless of the status of his/her account, and to accept the call and/or receive the calling subscriber's messages without the pre-paid credit account.

The calling subscriber dials the phone number of the called subscriber; the operator of the calling

subscriber determines his solvency; upon initiation of a call by the calling subscriber, who does not have a valid credit account, for its transmission to the called subscriber the outgoing call is directed through the operator serving the calling subscriber to a forwarding and controlling server and at its command disconnects the calling subscriber. The forwarding and controlling server processes the obtained information and forms a transit call, by the transit call through the operator serving the calling subscriber is transferred an outgoing call to the operator's network serving the called subscriber as an information call, notifying of the missed call. A notification about the missed call is created for the called subscriber. providing information about the calling subscriber, and the information call is disconnected after its receipt by the called subscriber.

The result, obtained by means of the claimed method, consists in increasing the reliability and ease of communication between subscribers in an irregular situation, namely upon insolvency of the calling subscriber.

[Consulter le mémoire](#)

(11) **16492**

(51) E04B 9/06 (2006.01)

(21) 1201300306 - PCT/IB11/051597

(22) 13.04.2011

(30) IT n° PD2011A000040 du 10/02/2011

(54) Deformable guide for partitions in general.

(73) Nicola CECCATO (IT)

(74) FANDIO & PARTNERS CONSULTING (SCP), Mendong, Route du Palais de Justice, Place du Marché, face Stade Wembley, B.P. 12246, YAOUNDE (CM).

(57) The invention is a deformable guide for partitions in general, comprising a plate strip that is die cut, cut and bent to form a U and has continuous sections (X) alternating with sections (Y) provided with cuts and holes (C, D, E). Each section (Y) with cuts and holes (C, D, E) is provided at least with cuts and holes (C, D) that are orthogonal to the edge of the plate strip and suited to divide said section (Y) into portions (Z), and wherein said portions (Z) are bent with respect to each other to form a 115° angle.

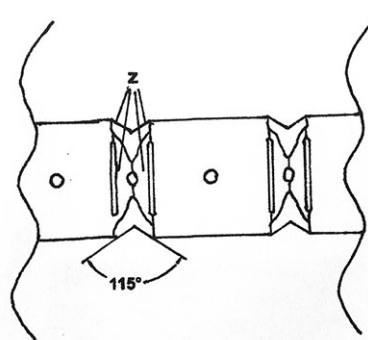

Fig. 2b

[Consulter le mémoire](#)

(11) **16493**

(51) C07D 471/04; A61P 35/00; A61K 31/4162

(21) 1201300307 - PCT/EP12/051283

(22) 27.01.2012

(30) FR n° 1150651 du 27/01/2011

(54) Derivatives of azaindazole or diazaindazole type as medicament.

(72) KALOUN El Bachir; BEDJEGUELAL Karim;

RABOT Rémi; KRUCZYNSKI Anna; SCHMITT Philippe; PEREZ Michel; RAHIER Nicolas.

(73) PIERRE FABRE MEDICAMENT (FR)

(74) Cabinet CAZENAVE SARL, B.P. 500, YAOUNDE (CM).

(57) The present invention relates to a compound of following formula (I) :

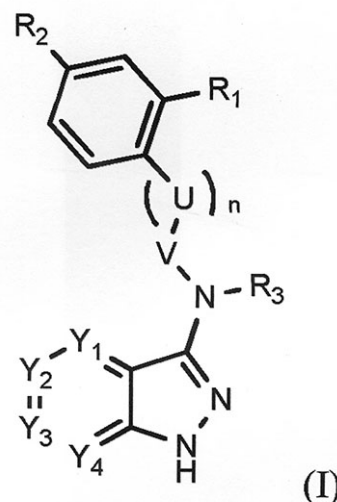

or a pharmaceutically acceptable salt or solvate of same, a tautomer of same, or a stereoisomer or mixture of stereoisomers of same in any proportions, such as a mixture of enantiomers, notably a racemic mixture; as well as to the use of same as a drug, notably intended for the

treatment of cancer, inflammation and neurodegenerative diseases such as Alzheimer's disease; to the use of same as a kinase inhibitor; to the pharmaceutical compositions comprising same; and to methods for the preparation of same.

[Consulter le mémoire](#)

(11) **16494**

(51) H02N 6/00 (2006.01)

(21) 1201300308 - PCT/CZ11/000076

(22) 03.08.2011

(30) CZ n° PV 2011-42 du 27/01/2011

(54) A photovoltaic element with an included resonator.

(72) PAVEL, Fiala, Hlaváčova.

(73) Vyzoké Ucení Technické v Brne (CZ)

(74) Cabinet ÉKÉMÉ LYSAGHT SARL, B.P. 6370, YAOUNDE (CM).

(57) A photovoltaic element including a resonator is arranged on a semiconductor structure (5) that is constituted by a region without electromagnetic damping (5a), whose upper plane forms the plane of incidence (3), and a region with electromagnetic damping (5b), both regions being bound by virtual boundaries (6) of variation in material properties. At least one 2D-3D resonator (4) is surrounded by a dielectric (10) and configured on the semiconductor structure (5), with a relative electrode (11) bordering on the region with electromagnetic damping (5b). The photovoltaic element having a resonator arranged on a semiconductor structure (5) uses the structure (5) and its characteristics to set suitable conditions for the impingement of an electromagnetic wave and its transformation to a stationary form of the electromagnetic field and not to secure the generation of an electric charge. The 2D-3D resonator produces electric current or voltage, which is conducted with the help of a nonlinear component (15) to a connecting component (16). The nonlinear element (15) shapes the signal on the resonant circuit; this signal is then filtered (rectified) to a further utilizable shape. The planar and spatial resonator (2D-3D resonator) is designed in such a manner that prevents the electromagnetic wave passing through the semiconductor structure (5) from

being reflected back to the 2D-3D resonator created in the structure (5). The semiconductor structure (5) does not generate a backward electromagnetic wave propagating in the direction of the impinging electromagnetic wave emitted by a source such as the Sun. The region with electromagnetic damping (5b) has the function of suppressing the reflected wave. Thus, the resonator behaves like an ideal impedance-matched component for the proposed frequency spectrum. The semiconductor structure (5) is set in such a manner that the conductivity increases in the electromagnetic damping region (5b) in the direction of the relative electrode (11), which leads to a wide resonance curve in the photovoltaic element components.

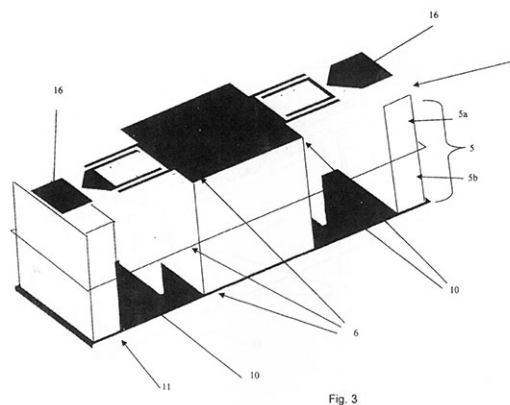

[Consulter le mémoire](#)

(11) **16495**

(51) A01N 43/40; A61K 31/44

(21) 1201300309 - PCT/US12/022815

(22) 27.01.2012

(30) US n° 61/437,027 du 28/01/2011

(54) Controlling mealybugs.

(72) YADAV, Mayank; RAMACHANDRAN, Suresh; KUNDU, Sanjoy.

(73) Dow AgroSciences LLC (US)

(74) Cabinet Spoor & Fisher Inc. Ngwafor & Partners, Blvd. du 20 Mai, Immeuble Centre Commercial de l'Hôtel Hilton, 2è Etage, Porte 208A, B.P. 8211, YAOUNDE (CM).

(57) The invention disclosed in this document concerns controlling mealybugs.

[Consulter le mémoire](#)

(11) 16496

(51) C07K 16/40; A61K 39/395; A61P 3/06

(21) 1201300310 - PCT/EP12/051321

(22) 27.01.2012

(30) EP n° 11305088,4 du 28/01/2011

EP n° 11305089.2 du 28/01/2011

EP n° 11305513.1 du 29/04/2011

EP n° 11305514.9 du 29/04/2011

EP n° 11306039.6 du 12/08/2011

EP n° 11306040.4 du 12/08/2011

EP n° 11306201.2 du 22/09/2011

EP n° 11306202.0 du 22/09/2011

EP n° 11306449.7 du 08/11/2011

EP n° 11306450.5 du 08/11/2011

(54) Pharmaceutical compositions comprising human antibodies to PCSK9.

(72) BESSAC, Laurence; CHAUDHARI, Umesh; HANOTIN, Corinne.

(73) Sanofi (FR)

(74) Cabinet Spoor & Fisher Inc. Ngwafor & Partners, Blvd. du 20 Mai, Immeuble Centre Commercial de l'Hôtel Hilton, 2è Etage, Porte 208A, B.P. 8211, YAOUNDE (CM).

(57) The present invention relates to pharmaceutical compositions comprising an antibody specifically binding to human proprotein convertase subtilisin/kexin type 9 (PCSK9), to methods for treating diseases or conditions in which proprotein convertase subtilisin/kexin type 9 (PCSK9) expression or activity causes an impact by administration of PCSK9-specific antibodies or antigen-binding fragments thereof and preferably by additional administration of an inhibitor of 3-hydroxy-3-methyl-glutaryl-CoA reductase (HMG-CoA reductase). The present invention further relates to PCSK9-specific antibodies or antigen-binding fragments thereof for use in the treatment of diseases or conditions in which PCSK9 expression or activity causes an impact.

The present invention also relates to articles of manufacture comprising packaging material,

PCSK9-specific antibodies or antigen-binding fragments thereof, and a label or packaging insert indicating which groups of patients can be treated with said antibodies or fragments, which groups of patients must not be treated with said antibodies or fragments, and which dosage regimen should be used.

The present invention further relates to methods of testing the efficacy of PCSK9-specific antibodies or antigen-binding fragments thereof for the treatment of certain diseases or conditions and for the treatment of specific sub-groups of patients.

[Consulter le mémoire](#)

(11) 16497

(51) B01D 1/16 (2006.01)

(21) 1201300311

(22) 29.07.2013

(54) Séchoir polyvalent.

(73) Monsieur NOLLA Isidore René, B.P. 4346, YAOUNDE (CM).

(57) Dispositif pour séchage et de déshydratation de tout type de grain, farine, fruits et autres.

L'invention concerne un dispositif polyvalent fixe ou mobile, se déployant au soleil et au vent, pouvant être assisté par un four à bois et charbon ou par des plaques solaires en vue de récupérer l'air chaud question d'accélérer le séchage.

Il est constitué des piliers d'angles (1) et centraux (2), des traverses (26) qui peuvent constituer l'ossature du séchoir, des coulisseaux (3) assurant le mouvement des tiroirs (4) superposés, se déployant sur les quatre côtés du séchoir, la bâche (7), contre la pluie et la rosée, des capteurs de vent (12), du grillage (5), d'un four (22), des collecteurs de fumée (16), d'un circuit serpenté de chaleur (19), d'un échappement (25), des vannes régulatrices (20), des aspirateurs pneumatiques (24) et (31), des répartiteurs de chaleur (23), de la nappe vibrante (28), des cames (30), des cordes (27), des pédales (8), des barres pesantes (32) qui peuvent guider la bâche sur la glissière (21) des battants (6).

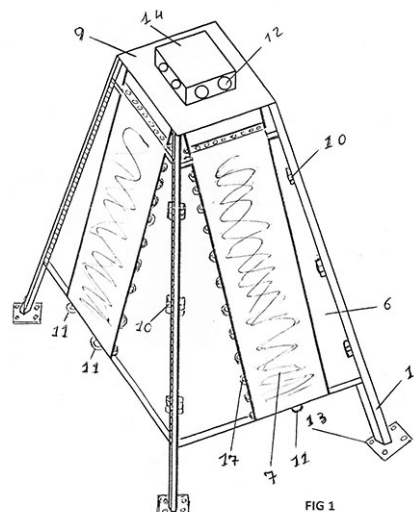

FIG 1

[Consulter le mémoire](#)

(11) **16498**

(51) C07C 229/50; A61P 31/18; A61P 31/22
A61P 31/16; A61P 17/06

(21) 1201300313 - PCT/RU12/000063

(22) 06.02.2012

(30) RU n° 2011103541 du 01/02/2011

(54) Hydrated N-fullerene amino acids, method for producing the latter, and pharmaceutical compositions on the basis thereof.

(72) RASNETSOV Lev Davidovich; SHVARTSMAN Iakov Yudelevich; SUVOROVA Olga Nikolaevna.

(73) RASNETSOV Lev Davidovich (RU)

(74) Cabinet ÉKÉMÉ LYSAGHT SARL, B.P. 6370, YAOUNDE (CM).

(57) The invention relates to the pharmaceutical industry and to medicine, specifically to novel hydrated amino-acid derivatives of fullerene C_{60} of general formula $C_{60}(H)_3\{NH(CH_2)_nCOOH\}_3 \cdot xH_2O$, where C_{60} - fullerene, $n = 5, 6, 7$, $x = 8 - 10$, and also to a method for producing said derivatives, and to the production of pharmaceutical compositions on the basis thereof. Hydrated N-fullerene amino acids are formed in the interaction of fullerene with 15 times the molar excess of anhydrous potassium salts of amino acids in a medium of organic aromatic solvent with slow addition to the resultant suspension of an interphase catalyst and with mixing and heating to a temperature not exceeding 60 °C until the

solution is completely decolorized and a solid residue formed, after which the latter is separated out, and then 0.8 M of aqueous solutions of potassium salts of fullerene amino-acid derivatives is treated with a solution of organic or mineral acids, followed by centrifugation, rinsing and drying of the residue. A pharmaceutical composition which exhibits activity against the herpes virus, flu viruses of various origin and HIV, and also anti-tumor and anti-psoriatic activity, comprising, as active substance, an effective quantity of hydrated N-fullerene amino acids.

[Consulter le mémoire](#)

(11) **16499**

(51) A01G 33/00 A23K 1/00 A23K 1/18
C12N 1/12

(21) 1201300314 - PCT/CH12/000029

(22) 03.02.2012

(30) CH n° 213/11 du 05/02/2011

(54) Vegetarian feeding method for carnivorous fish and shrimp with spirulina and chlorella algae using electrolysed water and sodium thiosulfate, guar and oligofractans as additives.

(73) STEFFEN, Hanspeter (CH)

(74) Cabinet Spoor & Fisher Inc. Ngwafor & Partners, Blvd. du 20 Mai, Immeuble Centre Commercial de l'Hôtel Hilton, 2è Etage, Porte 208A, B.P. 8211, YAOUNDE (CM).

(57) The invention relates to a feeding method and to the technology for producing a vegetarian food for carnivorous fish; the food is produced from Spirulina and Chlorella algae that are cultured and produced by cell proliferation in culture tanks in electrolysed nutrient water that has been treated with sodium thiosulfate to neutralise chlorine, and are subsequently dried and, with the addition of preferably 0.3% of guar gum powder and preferably 1-2% of oligofructan powder and with the addition of 10% electrolysed water for sterilisation, are pelleted and packaged. The fully vegetarian fish food produced by said method can be used for carnivorous fish without the fish suffering from diarrhoea. As a result, the water in the fish breeding tanks does not become immoderately eutrophic through excessive

turbidity-causing impurities, and at the same time the daily weight gain of the fish is not affected. In addition, an optimum daily growth rate and a fish flesh quality having optimum sensory properties can be achieved without the use of animal and fish-based proteins in the fish food ration. The administration of said novel, fully vegetarian fish food is also inexpensive and ecologically sustainable and ethically acceptable, since it contributes to the rescue of the remaining fish stocks in waters worldwide.

Fig. Anex 1

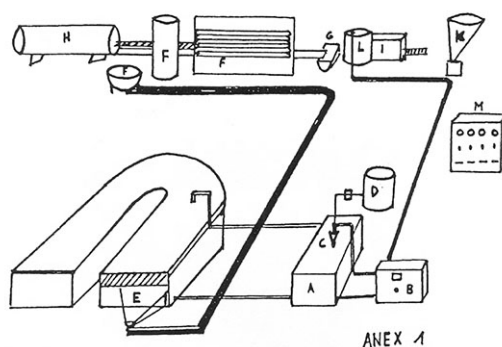

[Consulter le mémoire](#)

(11) **16500**

(51) A01N 25/34

(21) 1201300315 - PCT/US12/023932

(22) 06.02.2012

(30) US n° 61/440,003 du 07/02/2011

(54) Pesticidal compositions and processes related thereto.

(72) CROUSE, Gary D.; SPARKS, Thomas C.; DENT, William Hunter; MCLEOD, CaSandra Lee; CREEMER, Lawrence C.

(73) Dow AgroSciences LLC (US)

(74) Cabinet Spoor & Fisher Inc. Ngwafor & Partners, Blvd. du 20 Mai, Immeuble Centre Commercial de l'Hôtel Hilton, 2è Etage, Porte 208A, B.P. 8211, YAOUNDE (CM).

(57) This document discloses molecules having the following formulas ("Formula One" & "Formula Two" and "Formula Three")

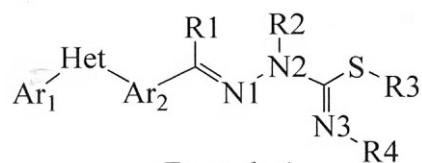

Formula 1

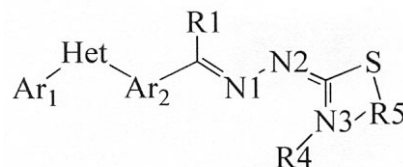

Formula 2

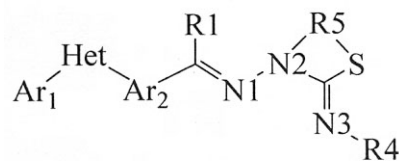

Formula 3

The Ar₁, Het, Ar₂, R¹, R², R³, R⁴, and R⁵ are further described herein.

[Consulter le mémoire](#)

(11) **16501**

(51) A01N 47/28; A61K 31/17

(21) 1201300316 - PCT/US12/024217

(22) 08.02.2012

(30) US n° 61/440,910 du 09/02/2011

(54) Pesticidal compositions and processes related thereto.

(72) CROUSE, Gary D.; LAMBERT, William Thomas; SPARKS, Thomas C.; HEGDE, Vidyadhar B.

(73) Dow AgroSciences LLC (US)

(74) Cabinet Spoor & Fisher Inc. Ngwafor & Partners, Blvd. du 20 Mai, Immeuble Centre Commercial de l'Hôtel Hilton, 2è Etage, Porte 208A, B.P. 8211, YAOUNDE (CM).

(57) This document discloses pesticidal compositions comprising molecules having the following formulas :

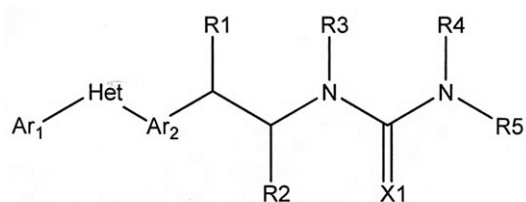

"Formula One"

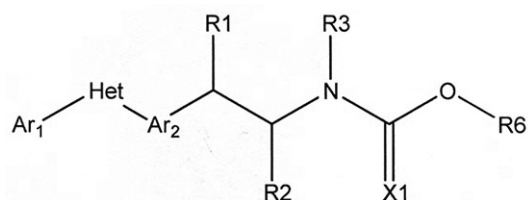

"Formula Two"

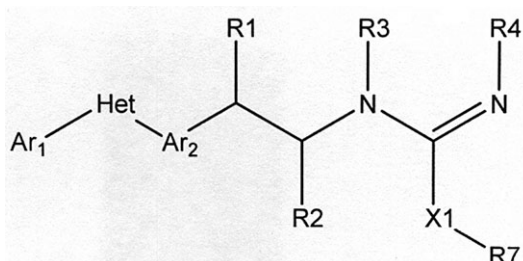

"Formula Three"

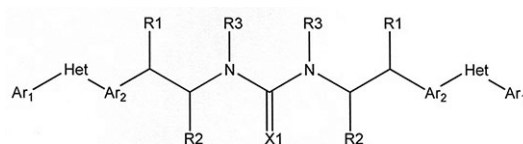

"Formula Four"

and processes related thereto.

[Consulter le mémoire](#)

(11) 16502

(51) B65D 88/12 (2006.01)

(21) 1201300317 - PCT/AU12/000097

(22) 02.02.2012

(30) AU n° 2011900323 du 02/02/2011

AU n° 2011900440 du 10/02/2011

AU n° 2011902466 du 23/06/2011

AU n° 2012100083 du 25/01/2012

AU n° 2012100084 du 25/01/2012

AU n° 2012100085 du 25/01/2012

(54) An improved container, container construction, handling method and apparatus.

(72) CHALMERS, Matthew William; PINDER, Garry Mark.

(73) Intermodal Solutions Pty Ltd (AU)

(74) Cabinet Spoor & Fisher Inc. Ngwafor & Partners, Blvd. du 20 Mai, Immeuble Centre Commercial de l'Hôtel Hilton, 2è Etage, Porte 208A, B.P. 8211, YAOUNDE (CM).

(57) The present invention provides a lid (400) for an open container (100, 13.10), a lid lifting system (13.100), a tippler (13.200) with the improved lid lifting system (13.100) and a method of lifting a container. The lid and lifting arrangement includes an apertured receiving formation (401) on an upper side of a lid (100) to receive a lift member (13.40). The lift member (13.40) can do one or more than one of the following: engaging the formation (401) will unlock a locking mechanism (13.42,458) holding the lid (400) to a container (100); or allow the lift member (13.40) to be rotated to thereby unlock the locking mechanism (13.42, 458) which locks the lid (400) to the container (100), while simultaneously locking the lift member (13.40, 458) to the lid (400). A lifting device which is able to perform such actions is also disclosed, and a method to operate the lifting device.

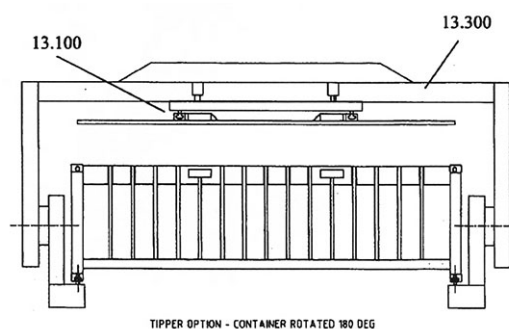

Fig 43

[Consulter le mémoire](#)

(11) 16503

(51) F16L 11/06 (2006.01)

(21) 1201300319 - PCT/GB12/050267

(22) 07.02.2012

(30) GB n° 1102388.4 du 10/02/2011

(54) Pipe.

(72) WOOD Alan; SANDNER Horst.

(73) Victrex Manufacturing Limited (GB)

(74) Cabinet ÉKÉMÉ LYSAGHT SARL, B.P. 6370, YAOUNDE (CM).

(57) A polyetheretherketone pipe of length greater than 250 meters and a residual stress of less than 5MPa may be made using a calibrator device (2) which includes a cone shaped opening (6) arranged to receive a molten extruded pipe shaped polymer. Attached to the front member (4) is a vacuum plate (14a) and successive vacuum

plates (14b-14h) are attached to one another to define an array of vacuum plates, the vacuum plates being arranged to allow a vacuum to be applied to a pipe precursor passing through opening (16). The vacuum plates (14) also include temperature control means for heating or cooling the plates and therefore heating or cooling a pipe precursor passing through the openings. With a vacuum applied to opening (6, 16) and heating/cooling the plates, an extruded hot plastics pipe is inserted into calibrator (2) via opening (6) and conveyed through opening (16) in plates (14), whereupon it is urged by the vacuum against the cylindrical surface defined by plates (14) to maintain its shape and the temperature of each plate is controlled to control the rate of cooling of the pipe precursor passing through. The pipe may be cooled at a relatively slow rate so that a pipe made from a relatively fast crystallising polymer crystallises and the crystallinity of the pipe along its extent and throughout its thickness is substantially constant.

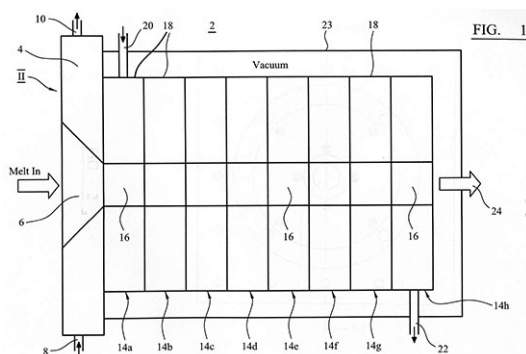

[Consulter le mémoire](#)

(11) **16504**

(51) C02F 3/00; C10G 32/00; C22B 3/18
C12M 1/38

(21) 1201300320 - PCT/IB12/000173

(22) 02.02.2012

(30) ZA n° 2011/00857 du 02/02/2011

(54) Apparatus and method for conducting microbiological processes.

(72) ERASMUS Johan; VAN HEERDEN Estariethe.

(73) University of The Free State (ZA)

(74) Cabinet ÉKÉMÉ LYSAGHT SARL,
B.P. 6370, YAOUNDE (CM).

(57) A method and apparatus are provided for conducting a microbiological process on a bulk material in which a quantity of the bulk material is loaded onto a waterproof lining forming part of a bio cell with a heat transfer arrangement below the quantity of bulk material or within its volume, or both. The moisture content of the bulk material is controlled by periodic or intermittent distribution of water into the bulk material in order to promote microbiological activity within the bulk material by means of microbes that may be either naturally occurring within the bulk material or may be selected and introduced into the bulk material according to a desired result. A leachate recovery installation collects leachate draining from the bulk material. The temperature within the bulk material is monitored and the temperature controlled in order to elevate or decrease the temperature thereof to approach a target temperature associated with enhanced microbial activity of microbes present within the bulk material. The apparatus includes a controller having an electronic micro-processor with the controller having inputs for association with a temperature detector and a moisture detector. The preferred apparatus includes solar powered thermal and electrical energy units.

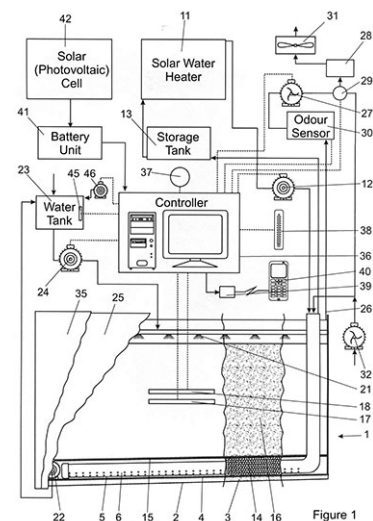

[Consulter le mémoire](#)

(11) **16505**

(51) F16L 3/015 (2006.01)

(21) 1201300321 - PCT/FR12/050137

(22) 23.01.2012

(30) FR n° 1150849 du 03/02/2011

(54) Limiteur de courbure de ligne flexible sous-marine et installation de liaison fond-surface en comprenant.

(72) PIONETTI François Régis; ROCHER Xavier.

(73) SAIPEM S.A. (FR)

(74) Cabinet CAZENAVE SARL, B.P. 500, YAOUNDE (CM).

(57) La présente invention concerne un dispositif limiteur de courbure constitué par la fixation, bout à bout, de manchons tubulaires (5), équipés en face supérieure à leurs extrémités longitudinales de dispositifs de fixation et articulation (6) et de butées inférieures (71, 72), diamétralement opposées en faces inférieures. La présente invention concerne également une installation de liaison fond-surface entre un équipement sous-marin, tel qu'une tête de puits sous-marine ou l'extrémité d'une conduite sous-marine reposant au fond de la mer (16), et un support flottant en surface (12), comprenant une ligne flexible sous-marine (2) dont la courbure est contrôlée par un dit dispositif limiteur de courbure (1) selon l'invention, ledit dispositif limiteur de courbure étant disposé à une profondeur intermédiaire entre le fond de la mer (16) et la surface (17).

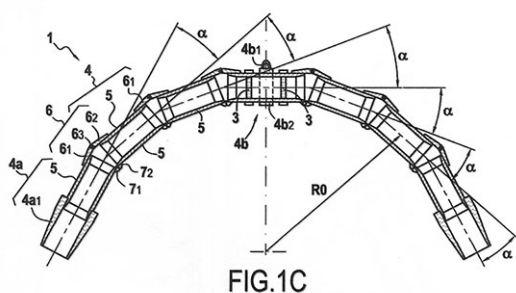

[Consulter le mémoire](#)

(11) **16506**

(51) C07D 207/34; C07D 231/12; C07D 233/61
C07D 249/08

(21) 1201300322 - PCT/IB12/050349

(22) 25.01.2012

(30) US n° 61/440,578 du 08/02/2011

US n° 61/441,044 du 09/02/2011

US n° 61/585,834 du 12/01/2012

(54) Glucagon receptor modulator.

(72) ASPNES, Gary Erik; DIDIUK, Mary Theresa;
FILIPSKI, Kevin James; GUZMAN-PEREZ, Angel;

LEE, Esther Cheng Yin; PFEFFERKORN, Jeffrey Allen; STEVENS, Benjamin Dawson; TU, Meihua Mike.

(73) PFIZER INC. (US)

(74) SCP AKKUM, AKKUM & Associates, Quartier Mballa II, Dragages, B.P. 4966, YAOUNDE (CM).

(57) The present invention provides a compound of Formula (I)

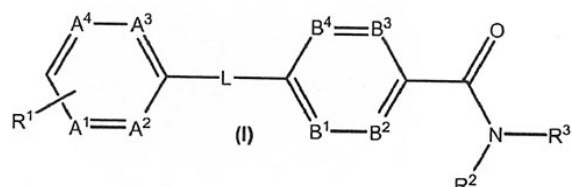

or a pharmaceutically acceptable salt thereof wherein R¹, R², R³, A¹, A², A³, A⁴, L, B¹, B², B³ and B⁴ are as defined herein. The compounds of Formula I have been found to act as glucagon antagonists or inverse agonists. Consequently, the compounds of Formula I and the pharmaceutical compositions thereof are useful for the treatment of diseases, disorders, or conditions mediated by glucagon.

[Consulter le mémoire](#)

(11) **16507**

(51) C12F 7/10; C12P 19/02

(21) 1201300323 - PCT/US12/025023

(22) 14.02.2012

(30) US n° 61/442,781 du 14/02/2011

(54) Processing biomass.

(72) MEDOFF, Marshall; MASTERMAN, Thomas.

(73) XYLECO, INC. (US)

(74) SCP AKKUM, AKKUM & Associates, Quartier Mballa II, Dragages, B.P. 4966, YAOUNDE (CM).

(57) Feedstocks, obtained at least in part from a plant material that has been modified with respect to its wild type, are processed to produce useful intermediates and products, such as energy, fuels, foods or materials. For example, systems are described that can treat such feedstock materials, e.g., to reduce the recalcitrance of the feedstock, and use the treated feedstock materials to produce an intermediate or product, e.g., by saccharification and/or fermentation.

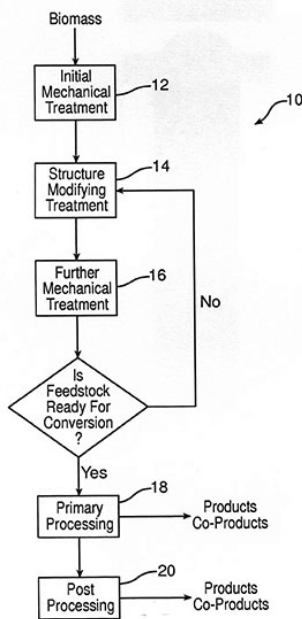

FIG. 1

[Consulter le mémoire](#)

(11) **16508**

(51) C12P 7/10; C12P 19/14; C12P 19/02
C13K 1/02

(21) 1201300324 - PCT/US12/024970

(22) 14.02.2012

(30) US n° 61/442,710 du 14/02/2011

(54) Processing paper feedstocks.

(72) MEDOFF, Marshall; MASTERMAN, Thomas.

(73) XYLECO, INC. (US)

(74) SCP AKKUM, AKKUM & Associates, Quartier Mballa II, Dragages, B.P. 4966, YAOUNDE (CM).

(57) Methods of processing paper feedstocks are provided, as well as intermediates and products made using such methods. Certain types of paper feedstocks, in particular highly pigmented papers, and/or highly loaded papers such as paper that has been color printed, e.g., magazines, and high basis weight coated papers, e.g., magazine stock, are utilized to produce useful intermediates and products, such as energy, fuels, foods or materials.

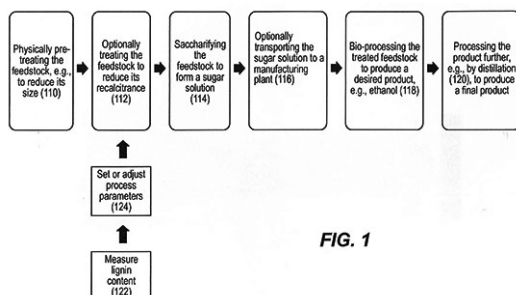

FIG. 1

[Consulter le mémoire](#)

(11) **16509**

(51) F01K 3/00 (2006.01)

(21) 1201300325 - PCT/MY12/000022

(22) 03.02.2012

(30) MY n° PI 2011000551 du 07/02/2011

MY n° PI 2011001755 du 19/04/2011

(54) Method and apparatus of producing and utilizing thermal energy in a combined heat and power plant.

(73) PALANISAMY, Krishna Moorthy (MY)

(74) SCP GLOBAL AFRICA IP, Base Buns, Mvog Betsi, (Sise Nouveau Marché), P.O. Box 3694, YAOUNDE (CM).

(57) Method and apparatus for operating a combined heat and power system with greater flexibility, reliability, control and stability, for providing operational flexibility and energy efficiency in operating a combined heat and power plant which includes a backpressure steam engine that expands a high temperature heat source of a thermodynamic fluid to generate mechanical power and discharge its spent heat for a beneficial use comprises a vessel subsystem for the spent heat, said vessel subsystem including: at least one main indirect heat exchange device or vessel (7) in heat exchange communication between its primary space (10) and its secondary space (11). The present invention also discloses the use of a method and apparatus to operate a combined heat and power system.

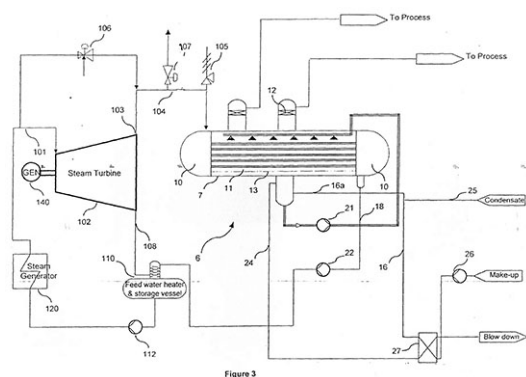

[Consulter le mémoire](#)

(11) **16510**

(51) C11B 1/16 (2006.01)

(21) 1201300326 - PCT/MY12/000021

(22) 03.02.2012

(30) MY n° PI 2011000551 du 07/02/2011

(54) Optimising the utilisation of renewable energy from biomass resources in the palm oil industry.

(73) PALANISAMY, Krishna Moorthy (MY)

(74) SCP GLOBAL AFRICA IP, Base Buns, Mvog Betsi, (Sise Nouveau Marché), P.O. Box 3694, YAOUNDE (CM).

(57) The invention provides an arrangement for operating energy system of a crude palm oil extraction plant and method thereof. The arrangement for operating energy system of a crude palm oil extraction plant achieves the target of higher efficiency of energy utilisation by using heat source at a low temperature featuring in the design operation point of the energy system providing thermal energy to the palm oil extraction process. Accordingly, the present invention provides an arrangement for operating energy system of a crude palm oil extraction plant which includes at least one heat source and at least one means to communicate heat from the at least one heat source to a unit process requiring heat energy wherein the energy system is designed and configured to operate at a design operation point for the temperature of the at least one heat source and wherein the at least one heat source temperature is between 115 °C and 141 °C. Preferably, the temperature of the at least one heat source is between 115 °C and 138 °C and the temperature of the at least one heat source is between 115 °C and 130 °C is more preferred. Most preferred is where the temperature of the at least one heat source is between greater than 100 °C and less than 115 °C.

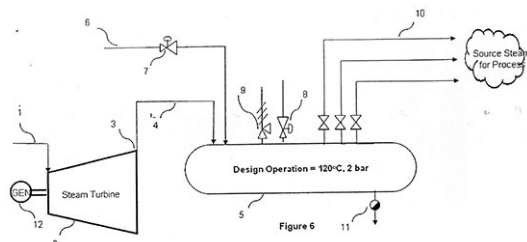

[Consulter le mémoire](#)

(11) **16511**

(51) A41G 3/00; A41G 5/00; C08L 63/00 C08L 67/02; D01F 6/92

(21) 1201300327 - PCT/JP13/063589

(22) 15.05.2013

(30) JP n° JP2012-112585 du 16/05/2012

(54) Polyester-based fiber for artificial hair and hair ornament product including the same, and method for producing the same.

(72) HIGAMI Tomokazu; HASHIMOTO Tomomichi; KAWAMURA Kohei; YORIZANE Mika.

(73) KANEKA CORPORATION (JP)

(74) Cabinet ÉKÉMÉ LYSAGHT SARL, B.P. 6370, YAOUNDE (CM).

(57) The present invention relates to a polyester-based fiber for artificial hair obtained by melt spinning a polyester resin composition. The polyester resin composition includes 100 parts by weight of a polyester resin, 5 to 40 parts by weight of a brominated epoxy flame retardant, and 1.5 parts by weight or more and less than 7 parts by weight of an antimony oxide. The polyester resin is at least one kind of resin selected from the group consisting of polyalkylene terephthalate and a copolymerized polyester containing polyalkylene terephthalate as a main component. The polyester-based fiber for artificial hair has aggregates of the brominated epoxy flame retardant that are dispersed in the polyester resin in the form of islands, as viewed in the cross section of the fiber parallel to the axis direction. The present invention also relates to hair ornament products including the polyester-based fiber for artificial hair and a method for producing the polyester-based fiber for artificial hair and a method for producing the polyester-based fiber for artificial hair. Thus, the present invention provides a polyester-based fiber for artificial hair having a gloss and a texture that similar to those of human hair, and hair ornament products including the polyester-based fiber for artificial hair.

[Consulter le mémoire](#)

(11) **16512**

(51) C07D 487/04; A61P 25/28; A61K 31/519

(21) 1201300329 - PCT/EP12/052378

(22) 13.02.2012

(30) EP n° 11154397.1 du 14/02/2011

EP n° PCT/EP2011/063705 du 09/08/2011

(54) 6-cyclobutyl-1,5-dihydro-pyrazolo[3,4-D]pyrimidin-4-one derivatives and their use as PDE9A inhibitors.

(72) HEINE Niklas; GIOVANNINI Riccardo; FERRARA Marco.

(73) Boehringer Ingelheim International GmbH (DE)

(74) Cabinet ÉKÉMÉ LYSAGHT SARL, B.P. 6370, YAOUNDE (CM).

(57) The invention relates to novel pyrazolopyrimidinones according to formula (I)

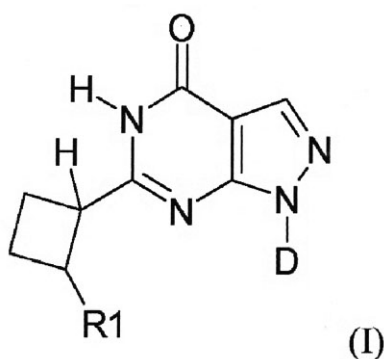

wherein R¹ is a pyridyl or pyrimidinyl group and D is optionally substituted cyclopentyl, cyclohexyl, tetrahydrofuranyl, tetrahydropyranyl or 2-, 3- or 4-pyridyl.

The new compounds are for use as the active entity of medicaments or for the manufacture of medicaments respectively, in particular medicaments for the treatment of conditions concerning deficits in perception, concentration, learning or memory. Such conditions may for example be associated with Alzheimer's disease, schizophrenia and other diseases. The new compounds are also for example for the manufacture of medicaments and/or for use in the treatment of these diseases, in particular for cognitive impairment associated with such disease. The compounds of the invention show PDE9 inhibiting properties.

[Consulter le mémoire](#)

(11) **16513**

(51) C04B 28/06; C04B 7/32; C09K 8/46

(21) 1201300488 - PCT/NO11/000271

(22) 26.09.2011

(30) NO n° 20110804 du 01/06/2011

(54) Cement composition based on calcium aluminate cement.

(72) REVIL, Philippe; PENG, Hong.

(73) Elkem AS (NO)

(74) Cabinet Spoor & Fisher Inc. Ngwafor & Partners, Blvd. du 20 Mai, Immeuble Centre Commercial de l'Hôtel Hilton, 2^e Etage, Porte 208A, P.O. Box 8211, YAOUNDE (CM).

(57) The present invention relates to a current composition for cementing oil or gas wells. The composition comprises calcium aluminate cement in which the proportion of HC203 is at least 50% by weight, dispersant, microsilica, mineral particles, water and optionally a retarder.

[Consulter le mémoire](#)

(11) **16514**

(51) F16L 1/12 (2006.01)

(21) 1201300370 - PCT/IB12/000639

(22) 05.03.2012

(30) GB n° 1103746.2 du 07/03/2011

(54) Abandonment and recovery system.

(72) MOUCHEL Cédric; MALOBERTI René.

(73) TECHNIP France (FR)

(74) Cabinet CAZENAVE SARL, B.P. 500, YAOUNDE (CM).

(57) A method of abandoning a pipeline being laid by a pipelaying vessel, wherein said pipeline is being held by a lay tower comprising a pipelaying and tensioning arrangement, comprising at least the steps of :

(a) linking the end of the pipeline (103) to a flexible tubular handling conduit (102);

(b) separately linking the pipeline to a lifting wire (104); and

(c) lowering the pipeline towards the sea floor. In this way, the present invention, using the load capacity of both a flexible tubular handling conduit and a lifting wire for at least some of the pipeline lowering, is able to operate either more safely at existing depths, or at even greater depths to an ocean floor than before, or both.

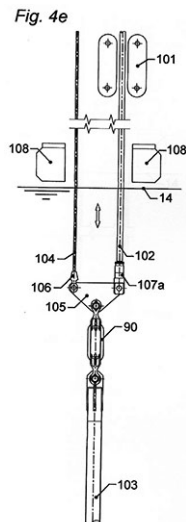

[Consulter le mémoire](#)

(11) **16515**

(51) A01H 5/10; C12Q 1/68

(21) 1201300398 - PCT/US06/020323

(22) 26.05.2006

(54) Soybean event MON89788 and methods for detection thereof.

(72) MALVEN Marianne; RINEHART Jennifer; TAYLOR Nancy; DICKINSON Ellen.

(73) Monsanto Technology LLC (US)

(74) Cabinet ÉKÉMÉ LYSAGHT SARL, B.P. 6370, YAOUNDE (CM).

(57) The present invention provides for soybean plant and seed comprising transformation event MON89788 and DNA molecules unique to these events. The invention also provides methods for detecting the presence of these DNA molecules in a sample.

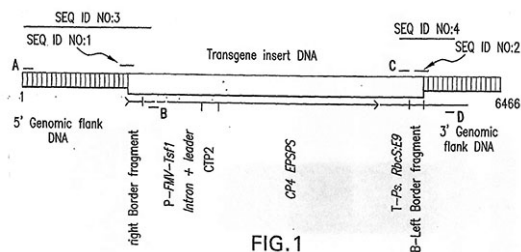

FIG. 1

[Consulter le mémoire](#)

B
REPERTOIRE SUIVANT LA C.I.B.

(51)	(11)
A01G 33/00	16499
A01H 5/10	16515
A01N 25/34	16500
A01N 29/04	16469
A01N 43/40	16495
A01N 47/28	16501
A23F 5/24	16482
A41G 3/00	16511
A61F 17/00	16470
A61K 9/08	16466
A61K 9/70	16483
A61K 31/12	16484
A61K 31/195	16473
A61K 35/64	16474
B01D 1/16 (2006.01)	16497
B01D 69/12 (2006.01)	16486
B01D 69/12 (2006.01)	16487
B23F 23/12 (2006.01)	16490
B62J 23/00 (2006.01)	16471
B65D 88/12 (2006.01)	16502
C01B 15/047	16467
C02F 3/00	16504
C04B 28/06	16513
C05F 15/00	16475
C07C 229/50	16498
C07C 231/02	16477
C07C 233/18	16476
C07D 207/34	16506
C07D 239/70	16485

(51)	(11)
C07D 403/12	16479
C07D 407/14	16478
C07D 471/04	16493
C07D 487/04	16480
C07D 487/04	16512
C07K 16/40	16496
C11B 1/16 (2006.01)	16510
C12F 7/10	16507
C12P 7/10	16508
C22B 1/02	16481
C22B 1/24	16488
C23C 16/50 (2006.01)	16468
E04B 9/06 (2006.01)	16492
E21B 43/00 (2006.01)	16489
F01K 3/00 (2006.01)	16509
F16L 1/12 (2006.01)	16514
F16L 1/15 (2006.01)	16472
F16L 3/015 (2006.01)	16505
F16L 11/06 (2006.01)	16503
H02N 6/00 (2006.01)	16494
H04M 3/42 (2006.01)	16491

C
REPERTOIRE DES NOMS

AREVA MINES et ERAMET
(11) 16481 (51) C22B 1/02
BAMBA Biti
(11) 16474 (51) A61K 35/64
Boehringer Ingelheim International GmbH
(11) 16478 (51) C07D 407/14
(11) 16479 (51) C07D 403/12
(11) 16480 (51) C07D 487/04
(11) 16485 (51) C07D 239/70
(11) 16512 (51) C07D 487/04
CECCATO Nicola
(11) 16492 (51) E04B 9/06 (2006.01)
CHERIF ZAHAR Kamal
(11) 16470 (51) A61F 17/00
CISSE Sidy Alpha
(11) 16490 (51) B23F 23/12 (2006.01)
COMURHEX SOCIETE POUR LA CONVERSION DE L'URANIUM EN METAL ET HEXAFLUORURE
(11) 16467 (51) C01B 15/047
D. LIGHT DESIGN, INC.
(11) 16468 (51) C23C 16/50 (2006.01)
Dow AgroSciences LLC
(11) 16495 (51) A01N 43/40
(11) 16500 (51) A01N 25/34
(11) 16501 (51) A01N 47/28
Elkem AS
(11) 16513 (51) C04B 28/06
GOLDEN BIOTECHNOLOGY CORPORATION
(11) 16484 (51) A61K 31/12
H. Lundbeck A/S
(11) 16469 (51) A01N 29/04
Intermodal Solutions Pty Ltd
(11) 16502 (51) B65D 88/12 (2006.01)
KANEKA CORPORATION
(11) 16511 (51) A41G 3/00
KONAN Kouassi Sylvain
(11) 16475 (51) C05F 15/00
LAUBHOUET Née LAVRY Blah Joachine (Madame)
(11) 16473 (51) A61K 31/195

MANSOUR, Rawya Lofty
(11) 16483 (51) A61K 9/70
Membrane Distillation Desalination Ltd. Co.
(11) 16486 (51) B01D 69/12 (2006.01)
(11) 16487 (51) B01D 69/12 (2006.01)
Monsanto Technology LLC
(11) 16515 (51) A01H 5/10
NDIAYE Abidine
(11) 16489 (51) E21B 43/00 (2006.01)
NICOLAESCU, Gheorghe
(11) 16491 (51) H04M 3/42 (2006.01)
NOLLA Isidore René (Monsieur)
(11) 16497 (51) B01D 1/16 (2006.01)
PALANISAMY, Krishna Moorthy
(11) 16509 (51) F01K 3/00 (2006.01)
(11) 16510 (51) C11B 1/16 (2006.01)
PFIZER INC.
(11) 16506 (51) C07D 207/34
PIERRE FABRE MEDICAMENT
(11) 16493 (51) C07D 471/04
RASNETSOV Lev Davidovich
(11) 16498 (51) C07C 229/50
Regeneron Pharmaceuticals, Inc.
(11) 16466 (51) A61K 9/08
SAIPEM S.A.
(11) 16505 (51) F16L 3/015 (2006.01)
Sanofi
(11) 16496 (51) C07K 16/40
SAQARA
(11) 16482 (51) A23F 5/24
SERVIER (LES LABORATOIRES)
(11) 16476 (51) C07C 233/18
(11) 16477 (51) C07C 231/02
STEFFEN, Hanspeter
(11) 16499 (51) A01G 33/00
TECHNIP FRANCE
(11) 16472 (51) F16L 1/15 (2006.01)
(11) 16514 (51) F16L 1/12 (2006.01)

TVS MOTOR COMPANY LIMITED		
(11)	16471	(51) B62J 23/00 (2006.01)
University of The Free State		
(11)	16504	(51) C02F 3/00
VALE S.A.		
(11)	16488	(51) C22B 1/24
Victrax Manufacturing Limited		
(11)	16503	(51) F16L 11/06 (2006.01)
Vyzoké Učení Technické v Brně		
(11)	16494	(51) H02N 6/00 (2006.01)
XYLECO, INC.		
(11)	16507	(51) C12F 7/10
(11)	16508	(51) C12P 7/10